

# Mercedes Benz SL-class 08y~ (R230)

WALD SPORTS LINE  
BLACK BISON EDITION

INSTALLATION MANUAL  
**WALD**  
Sportliche Autoausrüstung WALD International

THANK YOU FOR PURCHASING. THIS IS THE INSTALLATION MANUAL OF WALD FRONT BUMPER FOR MERCEDES-BENZ R230 SL-CLASS.  
PLEASE READ THIS MANUAL CAREFULLY BEFORE THE INSTALLATION.

ATTENTION



- ※ NO RETURNS CAN BE ACCEPTED BECAUSE OF IMPROPER INSTALLATION OR PAINTING.
- ※ CHECK THE FITMENT, AND ADJUST ALL THE DETAILS BEFORE PAINTING.
- We assume no responsibility for any damage resulting from improper installation, painting, modification and any cut wound in unsealing.
- Contact the car dealer when you have any question in removing OEM parts.
- During all the installation process, use parking brake and stop the engine completely.
- Use rasps or sandpapers to fit the products to the body if there is an individual difference.
- The product is made of FRP. Handle with care. Do not give the excessive force. Gradually fix the bolts and nuts by checking the fitment and balance of the installation.
- Check the fitment, and adjust all the details of the fitment steady and proper. Please check the fitment and all the details regularly, fix the bolts and nuts as necessary.
- The instruction of painting is just our recommendation, please paint it as you like.
- ※ PLEASE BE AWARE OF:
  - You may lose the warranty and all the services from the car maker, because of replacing OEM parts.
  - Reduced road clearance may cause inconvenience in using parking curbs and garage jack.
  - FRP, ABS and PPE products are slightly weaker than OEM parts in crashes.
  - The product may not match the body and OEM color perfectly.

Please purchase double sided tape, primer and caulking glue at auto accessory shop or hardware store.

Completely degrease and paint primer on all the installation positions to enhance the viscosity of double sided tape.  
Use dryer to warm double sided tape to enhance the viscosity in low temperature.  
Keep the car in a dry condition more than 24 hours after gluing.  
Do not wash the car during this time.

	PARTS	QUANTITIES
FRONT BUMPER	FRONT BUMPER	1
	TOW HOOK COVER	1
	MESHES	1 SET
	LED LAMP KIT	1 SET
	BRACKETS	2
	STUD BOLTS (M5)	2
	NUTS (M5)	4
	TAPPING SCREWS (M5 x 20)	2

Use caulking glue to fill the gap between the product and the body.



## FRONT BUMPER

### [BEFORE PAINTING]

- 1) Remove OEM front bumper according to the Mercedes-Benz service manual.
- 2) Relocate and temporarily install OEM headlight washer covers and use caulking glue to install the attached brackets to WALD Front Bumper from the rear.
- ※ Adjust the details of OEM headlight washer covers to make them work properly.
- 3) Temporarily install WALD Front Bumper to the body.
- ※ Adjust the details of WALD Front Bumper to fit the body by rasps or sandpapers.
- 4) Paint WALD Front Bumper according to the picture.

### [AFTER PAINTING]

- 5) Install PTS and the attached LED lamp kit to WALD Front Bumper.
- ※ Make sure the attached LED lamp kit is fine to work before the installation.
- 6) Use caulking glue to install the attached meshes to WALD Front Bumper from the rear.
- 7) Relocate OEM parts to WALD Front Bumper.
- 8) Temporarily fix all the tapping screws, clips, brackets, bolts and nuts to install WALD Front Bumper to the body.
- 9) Check all the details of the fitment, then fix them.

#### ■ LOCATION OF THE ATTACHED MESHES (STEP 6)

Use pins and caulking glue to install the attached meshes to WALD Front Bumper along the shape of the ducts from the rear.

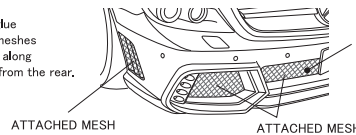

#### HOW TO INSTALL AMG BUMPER GRILLE

Use pins and caulking glue to install AMG bumper grille to WALD Front Bumper along the shape of the ducts from the rear.

#### ■ HOW TO INSTALL OEM BRACKETS

Use OEM brackets to fix WALD Front Bumper. (Exactly same with OEM installation process)

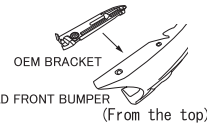

#### ■ HOW TO INSTALL OEM HEADLIGHT WASHER COVERS (STEP 2, 7)

(For AMG or Sport Package)

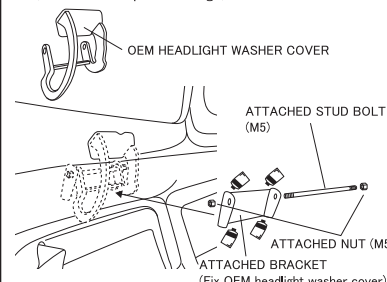

Use the attached brackets, stud bolts and nuts to install OEM headlight washer covers to WALD Front Bumper from the rear. Adjust the details of OEM headlight washer covers to make them work properly.

#### ■ WALD SHOWCAR IS PAINTED LIKE THE PICTURE (STEP 4)

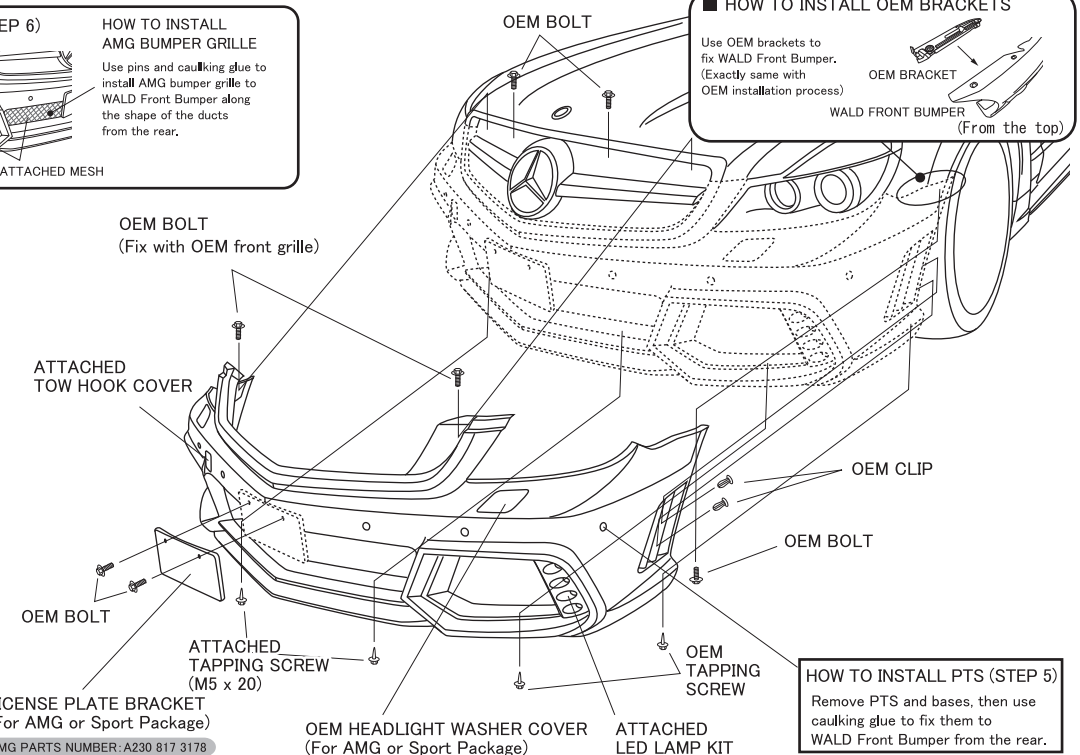
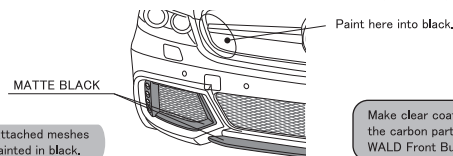

ATTENTION

- ※ MORE THAN 2 TECHNICIANS ARE NECESSARY IN THIS WORK.
- ※ DURING ALL THE INSTALLATION PROCESS, PLEASE BE CAREFUL NOT TO DAMAGE THE BODY.
- ※ REMOVE THE BATTERY BEFORE ALL THE WIRING WORKS.

LICENSE PLATE BRACKET (For AMG or Sport Package)  
AMG PARTS NUMBER: A230 817 3178

HOW TO INSTALL PTS (STEP 5)  
Remove PTS and bases, then use caulking glue to fix them to WALD Front Bumper from the rear.

# Mercedes Benz SL-class 08y~ (R230)

WALD SPORTS LINE  
BLACK BISON EDITION

INSTALLATION MANUAL  
**WALD**  
Sportliche Autoausrüstung WALD International

THANK YOU FOR PURCHASING. THIS IS THE INSTALLATION MANUAL OF WALD SIDE STEPS FOR MERCEDES-BENZ R230 SL-CLASS.  
PLEASE READ THIS MANUAL CAREFULLY BEFORE THE INSTALLATION.



- ※ NO RETURNS CAN BE ACCEPTED BECAUSE OF IMPROPER INSTALLATION OR PAINTING.
- ※ CHECK THE FITMENT, AND ADJUST ALL THE DETAILS BEFORE PAINTING.
- We assume no responsibility for any damage resulting from improper installation, painting, modification and any cut wound in unsealing.
- Contact the car dealer when you have any question in removing OEM parts.
- During all the installation process, use parking brake and stop the engine completely.
- Use rasps or sandpapers to fit the products to the body if there is an individual difference.
- The product is made of FRP. Handle with care. Do not give the excessive force. Gradually fix the bolts and nuts by checking the fitment and balance of the installation.
- Check the fitment, and adjust all the details of the fitment steady and proper. Please check the fitment and all the details regularly, fix the bolts and nuts as necessary.
- The instruction of painting is just our recommendation, please paint it as you like.
- ※ PLEASE BE AWARE OF:
  - You may lose the warranty and all the services from the car maker, because of replacing OEM parts.
  - Reduced road clearance may cause inconvenience in using parking curbs and garage jack.
  - FRP, ABS and PPE products are slightly weaker than OEM parts in crashes.
  - The product may not match the body and OEM color perfectly.

Please purchase double sided tape, primer and caulking glue at auto accessory shop or hardware store.

Completely degrease and paint primer on all the installation positions to enhance the viscosity of double sided tape.  
Use dryer to warm double sided tape to enhance the viscosity in low temperature.  
Keep the car in a dry condition more than 24 hours after gluing.  
Do not wash the car during this time.

	PARTS	QUANTITIES
SIDE STEP	SIDE STEPS	1 SET
	MESHES	1 SET

Use caulking glue to fill the gap between the product and the body.



## SIDE STEP

### 【BEFORE PAINTING】

- 1) Remove OEM side steps according to the Mercedes-Benz service manual.
- 2) Temporarily install WALD Side Steps to the body.
- ※ Adjust the details of WALD Side Steps to fit the body by rasps or sandpapers.

### 【AFTER PAINTING】

- 3) Use caulking glue to install the attached meshes to WALD Side Steps from the rear.
- 4) Install OEM rubber coverings to WALD Side Steps.
- 5) Temporarily fix OEM nuts, clips and tapping screws to install WALD Side Steps to the body.
- 6) Check all the details of the fitment, then fix them.
- 7) Install OEM rubber trim to WALD Side Steps.

#### ■ LOCATION OF THE ATTACHED MESHES (STEP 3)

Use pins and caulking glue to install the attached meshes to WALD Side Steps along the shape of the ducts from the rear.

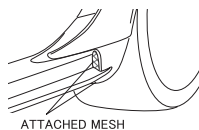

#### ⚠ ATTENTION

- ※ MORE THAN 2 TECHNICIANS ARE NECESSARY IN THIS WORK.
- ※ DURING ALL THE INSTALLATION PROCESS, PLEASE BE CAREFUL NOT TO DAMAGE THE BODY.
- ※ DEGREASE ALL THE INSTALLATION POSITIONS, AND REMOVE THE BODY PROTECTION COATING BEFORE THE INSTALLATION.

■ INCASE TO INSTALL (STEP 5)  
WALD FRONT SPORTS FENDERS  
Do not use OEM clips to fix WALD Side Steps with WALD Sports Fenders.

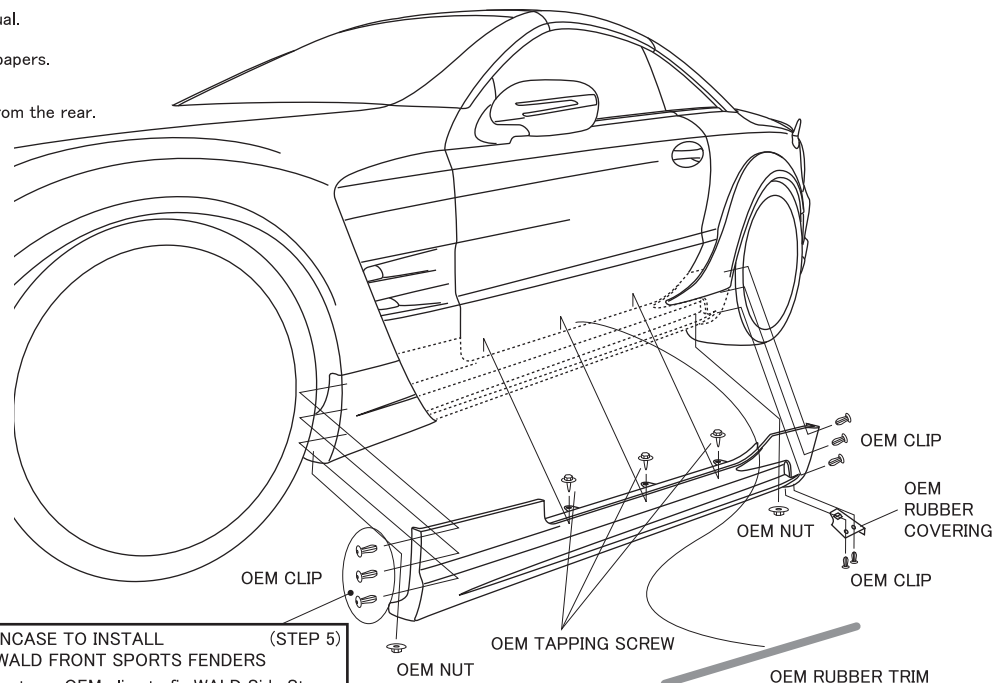

WALD INTERNATIONAL

# Mercedes Benz SL-class 08y~ (R230)

WALD SPORTS LINE  
BLACK BISON EDITION

INSTALLATION MANUAL  
**WALD**  
Sportliche Autoausrüstung WALD. International

THANK YOU FOR PURCHASING. THIS IS THE INSTALLATION MANUAL OF WALD REAR BUMPER FOR MERCEDES-BENZ R230 SL-CLASS.  
PLEASE READ THIS MANUAL CAREFULLY BEFORE THE INSTALLATION.

ATTENTION



- ※ NO RETURNS CAN BE ACCEPTED BECAUSE OF IMPROPER INSTALLATION OR PAINTING.
- ※ CHECK THE FITMENT, AND ADJUST ALL THE DETAILS BEFORE PAINTING.
- We assume no responsibility for any damage resulting from improper installation, painting, modification and any cut wound in unsealing.
- Contact the car dealer when you have any question in removing OEM parts.
- During all the installation process, use parking brake and stop the engine completely.
- Use rasps or sandpapers to fit the products to the body if there is an individual difference.
- The product is made of FRP. Handle with care. Do not give the excessive force. Gradually fix the bolts and nuts by checking the fitment and balance of the installation.
- Check the fitment, and adjust all the details of the fitment steady and proper. Please check the fitment and all the details regularly, fix the bolts and nuts as necessary.
- The instruction of painting is just our recommendation, please paint it as you like.
- ※ PLEASE BE AWARE OF:
  - You may lose the warranty and all the services from the car maker, because of replacing OEM parts.
  - Reduced road clearance may cause inconvenience in using parking curbs and garage jack.
  - FRP, ABS and PPE products are slightly weaker than OEM parts in crashes.
  - The product may not match the body and OEM color perfectly.

Please purchase double sided tape, primer and caulking glue at auto accessory shop or hardware store.

Completely degrease and paint primer on all the installation positions to enhance the viscosity of double sided tape.  
Use dryer to warm double sided tape to enhance the viscosity in low temperature.  
Keep the car in a dry condition more than 24 hours after gluing.  
Do not wash the car during this time.

	PARTS	QUANTITIES
REAR BUMPER	REAR BUMPER	1
	DIFFUSER FINS	4
	MESHES	1 SET
	LED LAMP	1
	LED REFLECTORS	2
	BRACKETS WITH NUTTERS	2
	BOLTS (M6 x 12)	8
	BOLTS (M5 x 15)	2

Use caulking glue to fill the gap between the product and the body.



## REAR BUMPER

### [BEFORE PAINTING]

- 1) Remove OEM rear bumper according to the Mercedes-Benz service manual.
- 2) Relocate OEM U-type nuts to WALD Rear Bumper.
- 3) Temporarily install WALD Rear Bumper to the body.
- ※ Adjust the details of WALD Rear Bumper to fit the body by rasps or sandpapers.
- 4) Prepare to connect the attached LED lamp.
- 5) Paint WALD Rear Bumper according to the picture.

### [AFTER PAINTING]

- 6) Install PTS, the attached diffuser fins and LED lamp to WALD Rear Bumper.
- ※ Make sure the attached LED lamp is fine to work before the installation.
- 7) Use caulking glue to install the attached meshes to WALD Rear Bumper from the rear.
- 8) Temporarily fix the all the brackets with nutters, U-type nuts, clips, tapping screws, bolts and nuts to install WALD Rear Bumper to the body.
- 9) Check all the details of the fitment, then fix them.

### ■ WALD SHOWCAR IS PAINTED LIKE THE PICTURE (STEP 5)

Make clear coating for the carbon parts of WALD Rear Bumper.

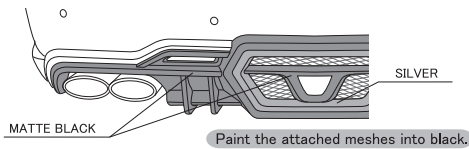

### ■ LOCATION OF THE ATTACHED MESHES (STEP 7)

Use pins and caulking glue to install the attached meshes to WALD Rear Bumper along the shape of the ducts from the rear.

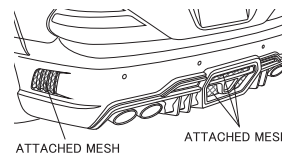

### ■ HOW TO INSTALL THE ATTACHED LED LAMP (STEP 6)

Cut the attached LED lamp to fit WALD Rear Bumper. Use caulking glue to make the attached LED lamp waterproof before the installation.

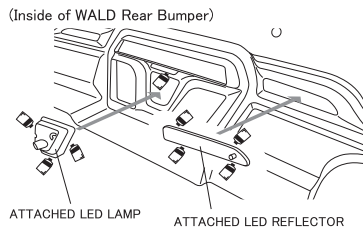

### ■ HOW TO INSTALL PTS (STEP 6)

Remove PTS and bases, then use caulking glue to fix them to WALD Rear Bumper from the rear.

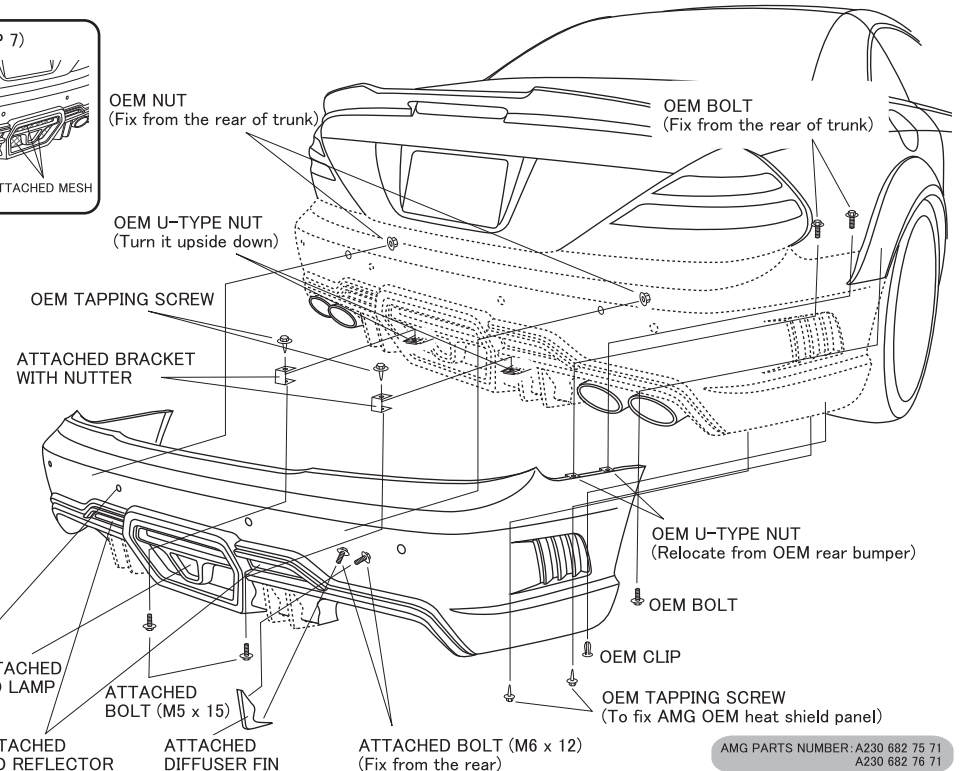

ATTENTION

- ※ MORE THAN 2 TECHNICIANS ARE NECESSARY IN THIS WORK.
- ※ DURING ALL THE INSTALLATION PROCESS, PLEASE BE CAREFUL NOT TO DAMAGE THE BODY.
- ※ REMOVE THE BATTERY BEFORE ALL THE WIRING WORKS.

AMG PARTS NUMBER: A230 682 75 71  
A230 682 76 71



# Mercedes Benz SL-class 08y~ (R230)

WALD SPORTS LINE  
BLACK BISON EDITION

INSTALLATION MANUAL  
**WALD**  
Sportliche Autoausrüstung WALD International

THANK YOU FOR PURCHASING. THIS IS THE INSTALLATION MANUAL OF WALD FRONT SPORTS FENDERS FOR MERCEDES-BENZ R230 SL-CLASS.  
PLEASE READ THIS MANUAL CAREFULLY BEFORE THE INSTALLATION.



- ※ NO RETURNS CAN BE ACCEPTED BECAUSE OF IMPROPER INSTALLATION OR PAINTING.
- ※ CHECK THE FITMENT, AND ADJUST ALL THE DETAILS BEFORE PAINTING.
- We assume no responsibility for any damage resulting from improper installation, painting, modification and any cut wound in unsealing.
- Contact the car dealer when you have any question in removing OEM parts.
- During all the installation process, use parking brake and stop the engine completely.
- Use rasps or sandpapers to fit the products to the body if there is an individual difference.
- The product is made of FRP. Handle with care. Do not give the excessive force. Gradually fix the bolts and nuts by checking the fitment and balance of the installation.
- Check the fitment, and adjust all the details of the fitment steady and proper. Please check the fitment and all the details regularly, fix the bolts and nuts as necessary.
- The instruction of painting is just our recommendation, please paint it as you like.
- ※ PLEASE BE AWARE OF:
  - You may lose the warranty and all the services from the car maker, because of replacing OEM parts.
  - Reduced road clearance may cause inconvenience in using parking curbs and garage jack.
  - FRP, ABS and PPE products are slightly weaker than OEM parts in crashes.
  - The product may not match the body and OEM color perfectly.

Please purchase double sided tape, primer and caulking glue at auto accessory shop or hardware store.

Completely degrease and paint primer on all the installation positions to enhance the viscosity of double sided tape.  
Use dryer to warm double sided tape to enhance the viscosity in low temperature.  
Keep the car in a dry condition more than 24 hours after gluing.  
Do not wash the car during this time.

	PARTS	QUANTITIES
FRONT SPORTS FENDER	FRONT SPORTS FENDERS	1 SET
	TAPPING SCREWS (M4 x 13)	10

Use caulking glue to fill the gap between the product and the body.



## FRONT SPORTS FENDER

### [BEFORE PAINTING]

- 1) Remove OEM front fenders according to the Mercedes-Benz service manual.
- 2) Temporarily install WALD Front Sports Fenders to the body.
- 3) Adjust the details of WALD Front Sports Fenders to fit the body by rasps or sandpapers.
- 4) Mark the installation positions on the body according to OEM inner liners to insert the attached tapping screws.
- 5) Remove WALD Front Sports Fenders, then make holes on the body according to the marked positions.

### [AFTER PAINTING]

- 6) Install OEM ducts to WALD Front Sports Fenders.
- 7) Completely degrease the installation positions, then temporarily fix the attached tapping screws, OEM ducts, bolts and nuts to install WALD Front Sports Fenders to the body.
- 8) Check all the details of the fitment, then fix them.
- 9) Leave them till completely fixed.

### ■ HOW TO INSTALL OEM DUCTS (STEP 5)

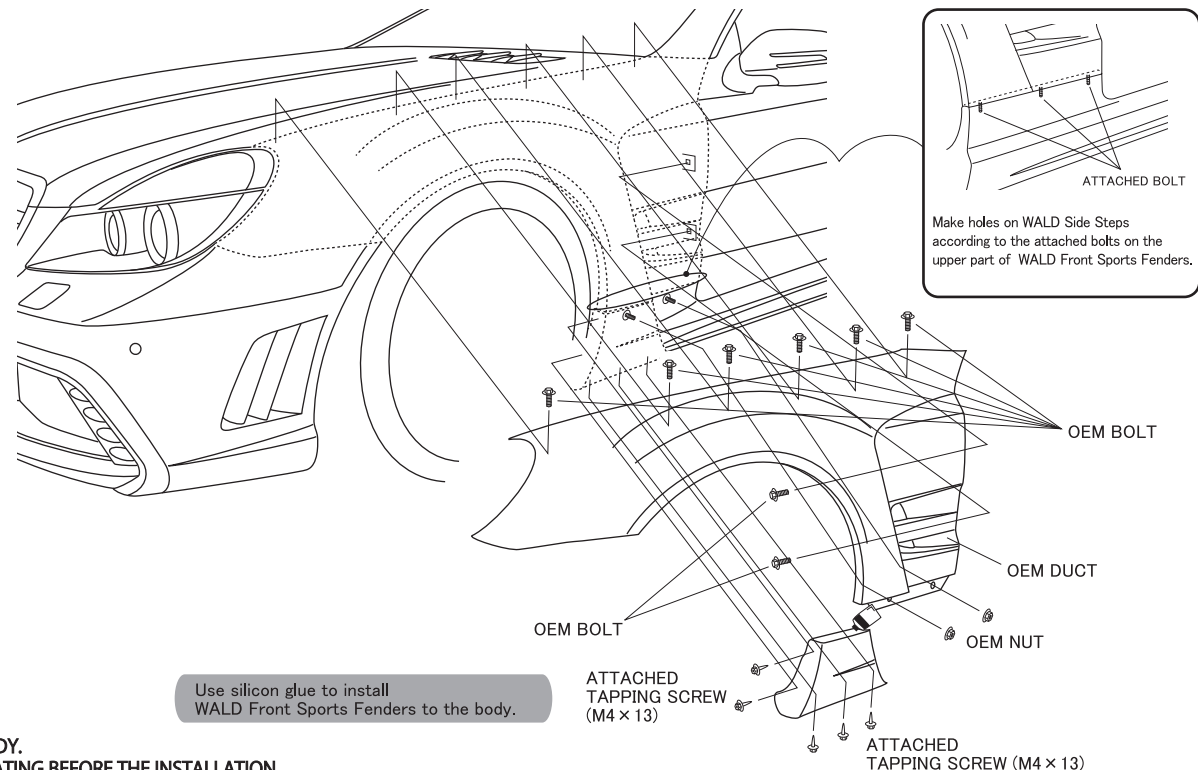
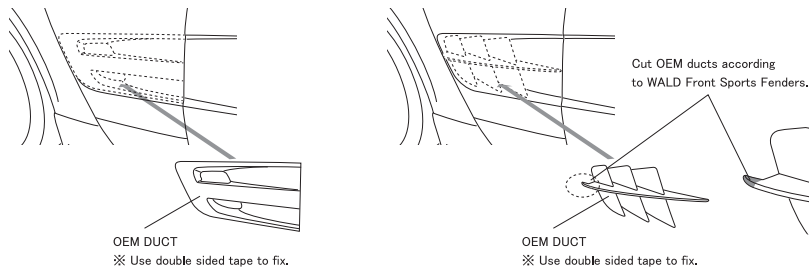

Use silicon glue to install WALD Front Sports Fenders to the body.



ATTENTION ※ MORE THAN 2 TECHNICIANS ARE NECESSARY IN THIS WORK.  
※ DURING ALL THE INSTALLATION PROCESS, PLEASE BE CAREFUL NOT TO DAMAGE THE BODY.  
※ DEGREASE ALL THE INSTALLATION POSITIONS, AND REMOVE THE BODY PROTECTION COATING BEFORE THE INSTALLATION.

# Mercedes Benz SL-class 08y~ (R230)

WALD SPORTS LINE  
BLACK BISON EDITION

INSTALLATION MANUAL  
**WALD**  
Sportliche Autoausrüstung WALD International

THANK YOU FOR PURCHASING. THIS IS THE INSTALLATION MANUAL OF WALD OVER FENDERS FOR MERCEDES-BENZ R230 SL-CLASS.  
PLEASE READ THIS MANUAL CAREFULLY BEFORE THE INSTALLATION.

## ATTENTION



- ※ NO RETURNS CAN BE ACCEPTED BECAUSE OF IMPROPER INSTALLATION OR PAINTING.
- ※ CHECK THE FITMENT, AND ADJUST ALL THE DETAILS BEFORE PAINTING.
- We assume no responsibility for any damage resulting from improper installation, painting, modification and any cut wound in unsealing.
- Contact the car dealer when you have any question in removing OEM parts.
- During all the installation process, use parking brake and stop the engine completely.
- Use rasps or sandpapers to fit the products to the body if there is an individual difference.
- The product is made of FRP. Handle with care. Do not give the excessive force. Gradually fix the bolts and nuts by checking the fitment and balance of the installation.
- Check the fitment, and adjust all the details of the fitment steady and proper. Please check the fitment and all the details regularly, fix the bolts and nuts as necessary.
- The instruction of painting is just our recommendation, please paint it as you like.
- ※ PLEASE BE AWARE OF:
  - You may lose the warranty and all the services from the car maker, because of replacing OEM parts.
  - Reduced road clearance may cause inconvenience in using parking curbs and garage jack.
  - FRP, ABS and PPE products are slightly weaker than OEM parts in crashes.
  - The product may not match the body and OEM color perfectly.

Please purchase double sided tape, primer and caulking glue at auto accessory shop or hardware store.

Completely degrease and paint primer on all the installation positions to enhance the viscosity of double sided tape.  
Use dryer to warm double sided tape to enhance the viscosity in low temperature.  
Keep the car in a dry condition more than 24 hours after gluing.  
Do not wash the car during this time.

	PARTS	QUANTITIES
OVER FENDER	OVER FENDERS	1 SET
	TAPPING SCREWS (M4 x 13)	6

Use caulking glue to fill the gap between the product and the body.

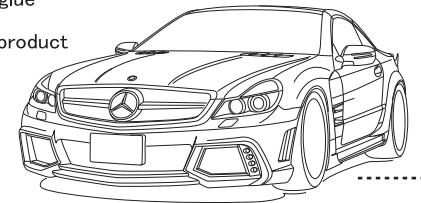

## OVER FENDER

### [BEFORE PAINTING]

- 1) Temporarily install WALD Over Fenders to the body.
- ※ Adjust the details of WALD Over Fenders to fit the body by rasps or sandpapers.
- 2) Check the fitment, then use masking tape to mark the installation positions.
- 3) Mark the installation positions on the body according to WALD Over Fenders to insert the attached tapping screws.
- 4) Remove WALD Over Fenders, then make holes on the body according to the marked positions.

Process OEM rear fenders according to the size of wheels.

### [AFTER PAINTING]

- 5) Completely degrease the installation positions, then use caulking glue to install WALD Over Fenders to the body according to the marked positions.
- 6) Temporarily fix the attached tapping screws.
- 7) Check all the details of the fitment, then fix them.
- 8) Leave them till completely fixed.

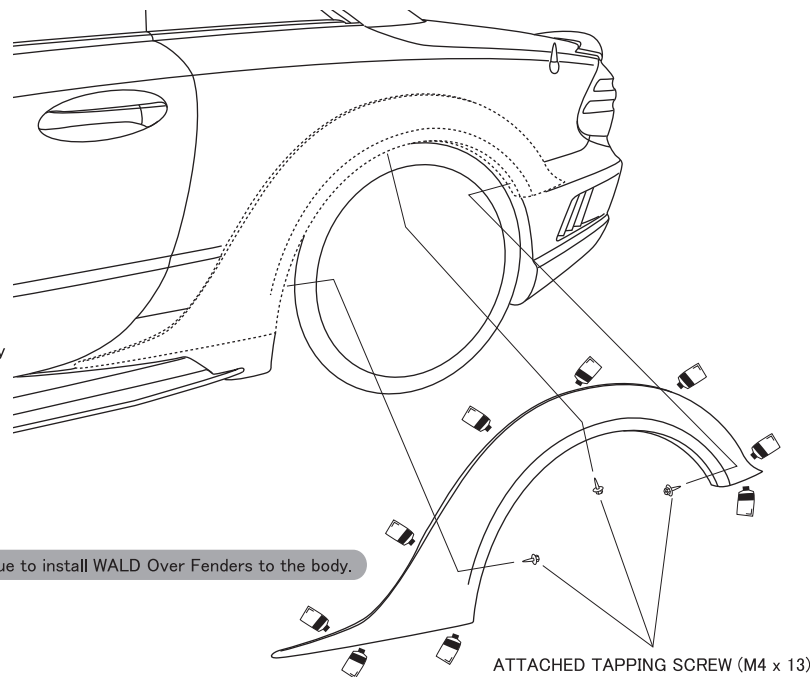

## ATTENTION

- ※ MORE THAN 2 TECHNICIANS ARE NECESSARY IN THIS WORK.
- ※ DURING ALL THE INSTALLATION PROCESS, PLEASE BE CAREFUL NOT TO DAMAGE THE BODY.
- ※ DEGREASE ALL THE INSTALLATION POSITIONS, AND REMOVE THE BODY PROTECTION COATING BEFORE THE INSTALLATION.

# Mercedes Benz SL-class 08y~ (R230)

WALD SPORTS LINE  
BLACK BISON EDITION

INSTALLATION MANUAL  
**WALD**  
Sportliche Autoausrüstung WALD. International

THANK YOU FOR PURCHASING. THIS IS THE INSTALLATION MANUAL OF WALD TRUNK SPOILER FOR MERCEDES-BENZ R230 SL-CLASS.  
PLEASE READ THIS MANUAL CAREFULLY BEFORE THE INSTALLATION.

## ATTENTION



- ※ NO RETURNS CAN BE ACCEPTED BECAUSE OF IMPROPER INSTALLATION OR PAINTING.
- ※ CHECK THE FITMENT, AND ADJUST ALL THE DETAILS BEFORE PAINTING.
- We assume no responsibility for any damage resulting from improper installation, painting, modification and any cut wound in unsealing.
- Contact the car dealer when you have any question in removing OEM parts.
- During all the installation process, use parking brake and stop the engine completely.
- Use rasps or sandpapers to fit the products to the body if there is an individual difference.
- The product is made of FRP. Handle with care. Do not give the excessive force. Gradually fix the bolts and nuts by checking the fitment and balance of the installation.
- Check the fitment, and adjust all the details of the fitment steady and proper. Please check the fitment and all the details regularly, fix the bolts and nuts as necessary.
- The instruction of painting is just our recommendation, please paint it as you like.
- ※ PLEASE BE AWARE OF:
  - You may lose the warranty and all the services from the car maker, because of replacing OEM parts.
  - Reduced road clearance may cause inconvenience in using parking curbs and garage jack.
  - FRP, ABS and PPE products are slightly weaker than OEM parts in crashes.
  - The product may not match the body and OEM color perfectly.

Please purchase double sided tape, primer and caulking glue at auto accessory shop or hardware store.

Completely degrease and paint primer on all the installation positions to enhance the viscosity of double sided tape.  
Use dryer to warm double sided tape to enhance the viscosity in low temperature.  
Keep the car in a dry condition more than 24 hours after gluing.  
Do not wash the car during this time.

	PARTS	QUANTITIES
TRUNK SPOILER	TRUNK SPOILER	1



Use caulking glue to fill the gap between the product and the body.

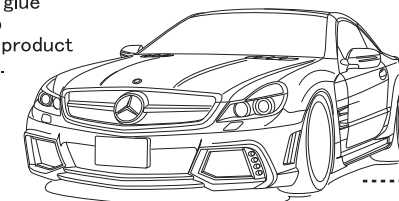

## TRUNK SPOILER

### [BEFORE PAINTING]

- 1) Temporarily install WALD Trunk Spoiler to the body.
- 2) Check the fitment, then use masking tape to mark the installation position.

### [AFTER PAINTING]

- 3) Completely degrease the installation position, then use caulking glue to install WALD Trunk Spoiler to the body according to the marked position.
- 4) Check all the details of the fitment, leave them till completely fixed.

Make clear coating for the carbon parts of WALD Trunk Spoiler.

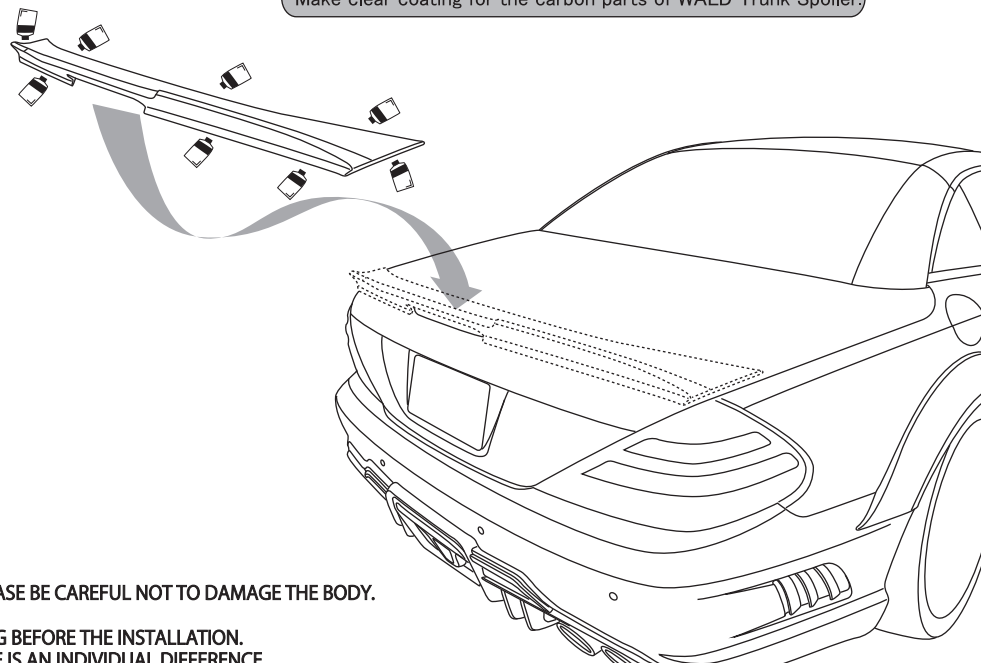

## ATTENTION

- ※ DURING ALL THE INSTALLATION PROCESS, PLEASE BE CAREFUL NOT TO DAMAGE THE BODY.
- ※ DEGREASE THE INSTALLATION POSITION, AND REMOVE THE BODY PROTECTION COATING BEFORE THE INSTALLATION.
- ※ ADJUST THE DETAILS OF THE FITMENT IF THERE IS AN INDIVIDUAL DIFFERENCE.



WALD.INTERNATIONAL

WALD. INTERNATIONAL

ADD: 10-13 KYOGUCHI-CHO, TAKATSUKI, OSAKA, JAPAN ZIP: 569-0072 TEL: (81)-72-673-3000 FAX: (81)-72-673-3003

WALD.INTERNATIONAL

# Mercedes Benz SL-class 08y~ (R230)

WALD SPORTS LINE  
BLACK BISON EDITION

INSTALLATION MANUAL  
**WALD**  
Sportliche Autoausrüstung WALD. International

THANK YOU FOR PURCHASING. THIS IS THE INSTALLATION MANUAL OF LED LAMP KIT OF WALD FRONT BUMPER FOR MERCEDES-BENZ R230 SL-CLASS.  
PLEASE READ THIS MANUAL CAREFULLY BEFORE THE INSTALLATION.

ATTENTION



- ※ NO RETURNS CAN BE ACCEPTED BECAUSE OF IMPROPER INSTALLATION OR PAINTING.
- ※ CHECK THE FITMENT, AND ADJUST ALL THE DETAILS BEFORE PAINTING.
- We assume no responsibility for any damage resulting from improper installation, painting, modification and any cut wound in unsealing.
- Contact the car dealer when you have any question in removing OEM parts.
- During all the installation process, use parking brake and stop the engine completely.
- Use rasps or sandpapers to fit the products to the body if there is an individual difference.
- The product is made of FRP. Handle with care. Do not give the excessive force. Gradually fix the bolts and nuts by checking the fitment and balance of the installation.
- Check the fitment, and adjust all the details of the fitment steady and proper. Please check the fitment and all the details regularly, fix the bolts and nuts as necessary.
- The instruction of painting is just our recommendation, please paint it as you like.
- ※ PLEASE BE AWARE OF:
  - You may lose the warranty and all the services from the car maker, because of replacing OEM parts.
  - Reduced road clearance may cause inconvenience in using parking curbs and garage jack.
  - FRP, ABS and PPE products are slightly weaker than OEM parts in crashes.
  - The product may not match the body and OEM color perfectly.

Please purchase double sided tape, primer and caulking glue at auto accessory shop or hardware store.

Completely degrease and paint primer on all the installation positions to enhance the viscosity of double sided tape.  
Use dryer to warm double sided tape to enhance the viscosity in low temperature.  
Keep the car in a dry condition more than 24 hours after gluing.  
Do not wash the car during this time.

	PARTS	QUANTITIES
LED LAMP KIT	LED LAMPS	1 SET
	LED LAMP BRACKETS	1 SET
	BOLTS (M5 x 15)	6
	RESISTORS (25W, 10Ω)	2



Use caulking glue to fill the gap between the product and the body.

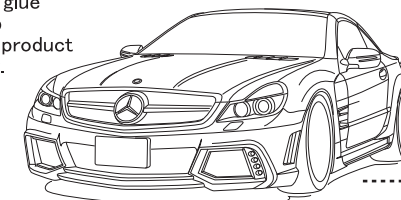

## LED LAMP KIT

### [BEFORE PAINTING]

- 1) Temporarily fix the attached bolts to install the LED lamp brackets to WALD Front Bumper from the rear.
- ※ Adjust the details of WALD Front Bumper and the LED lamp brackets to fit by rasps or sandpapers.
- 2) Check the position and angle of the LED lamps to fit the LED lamp brackets.
- ※ Adjust the details of the LED lamp brackets to fit the LED lamps by rasps or sandpapers.
- 3) Prepare to connect the LED lamps.
- ※ Insulate any spare harness.
- 4) Paint the LED lamp brackets according to the picture.

### [AFTER PAINTING]

- 5) Check all the details of the fitment, then use caulking glue to fix the LED lamps to the LED lamp brackets.
- 6) Use masking tape to fix the LED lamps to the LED lamp brackets, leave them till completely fixed.
- 7) Install them to WALD Front Bumper.

### ■ WALD SHOWCAR IS PAINTED LIKE THE PICTURE (STEP 4)

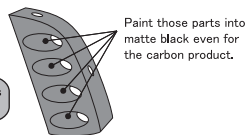

Make clear coating for the carbon parts of the LED lamp brackets.



ATTENTION

- ※ DEGREASE ALL THE INSTALLATION POSITIONS, AND REMOVE THE BODY PROTECTION COATING BEFORE THE INSTALLATION.
- ※ REMOVE THE BATTERY BEFORE ALL THE WIRING WORKS.
- ※ MAKE SURE THE LED LAMPS ARE FINE TO WORK BEFORE THE INSTALLATION.

### ■ HOW TO INSTALL THE LED LAMPS (STEP 2, 5)

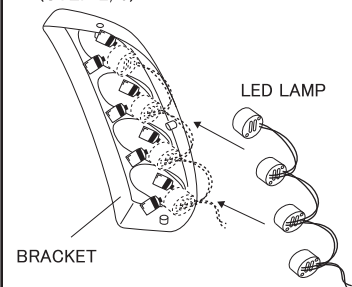

ABOUT THE LED LAMP  
(Face of the lens)

Fix the LED lamps to the LED lamp brackets according to the picture.

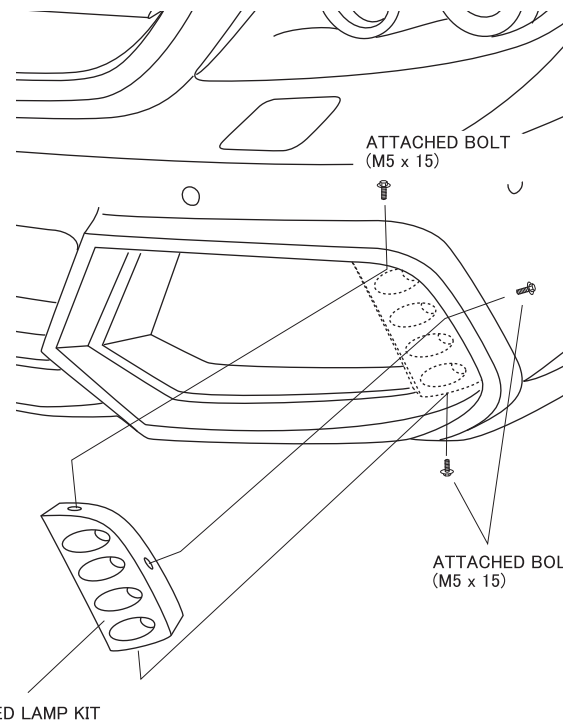

### = WIRING DIAGRAM =

#### [ AS FOG LAMP ]

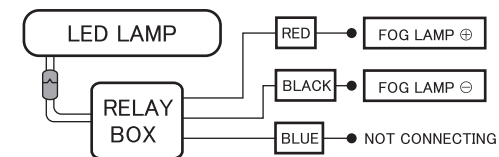

#### [ AS DAYLIGHT ]

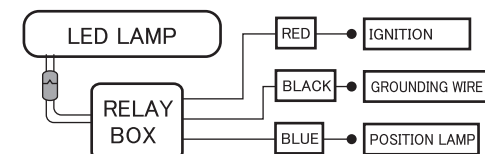

- Install the attached resistors away from the harness to prevent the heat of them.

CAR SIDE