

BMW 7 Series F01/02

WALD SPORTS LINE
BLACK BISON EDITION

INSTALLATION MANUAL
WALD
Sportliche Autoausrüstung WALD.International

THANK YOU FOR PURCHASING. THIS IS THE INSTALLATION MANUAL OF WALD FRONT BUMPER FOR BMW F01/02 7 SERIES.

ATTENTION



- ※ NO RETURNS CAN BE ACCEPTED BECAUSE OF IMPROPER INSTALLATION OR PAINTING.
- ※ CHECK THE FITMENT, AND ADJUST ALL THE DETAILS BEFORE PAINTING.
- We assume no responsibility for any damage resulting from improper installation, painting, modification and any cut wound in unsealing.
- Contact the car dealer when you have any question in removing OEM parts.
- During all the installation process, use parking brake and stop the engine completely.
- Use rasps or sandpapers to fit the products to the body if there is an individual difference.
- The product is made of FRP. Handle with care. Do not give the excessive force.
- Gradually fix the bolts and nuts by checking the fitment and balance of the installation.
- After making a hole on the body, make the corrosion treatment on it.
- Check the fitment, and adjust all the details of the fitment steady and proper.
- Please check the fitment and all the details regularly, fix the bolts and nuts as necessary.
- The instruction of painting is just our recommendation, please paint it as you like.
- ※ PLEASE BE AWARE OF:
- You may lose the warranty and all the services from the car maker, because of replacing OEM parts.
- Reduced road clearance may cause inconvenience in using parking curbs and garage jack.
- FRP, ABS and PPE products are slightly weaker than OEM parts in crashes.
- The product may not match the body and OEM color perfectly.

Please purchase double sided tape, primer and caulking glue at auto accessory shop or hardware store.

Completely degrease and paint primer on all the installation positions to enhance the viscosity of double sided tape.

Use dryer to warm double sided tape to enhance the viscosity in low temperature.

Keep the car in a dry condition more than 24 hours after gluing.

Do not wash the car during this time.

	PARTS	QUANTITIES
FRONT BUMPER	FRONT BUMPER	1
	LICENSE PLATE BRACKET	1
	MESHES	1 SET
	LED LAMPS (LIGHT REDUCTION)	1 SET
	BOLTS (M6 x 12)	6
	NUTS (M6)	2
	RESISTORS (25W, 10Ω)	2

Use caulking glue to fill the gap between the product and the body.

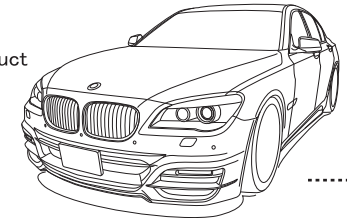

FRONT BUMPER

[BEFORE PAINTING]

- 1) Remove OEM front bumper according to the BMW service manual.
- 2) Temporarily install WALD Front Bumper to the body.
- ※ Adjust the details of WALD Front Bumper to fit the body by rasps or sandpapers.
- 3) Prepare to connect the attached LED lamp harness and install the attached resistors.
- 4) Paint WALD Front Bumper according to the picture.

[AFTER PAINTING]

- 5) Relocate OEM headlight washer parts, PTS, moldings and the attached license plate bracket to WALD Front Bumper.
- 6) Install the attached LED lamps to WALD Front Bumper.
- ※ Make sure the attached LED lamps are fine to work before the installation.
- 7) Use pins and caulking glue to install the attached meshes to WALD Front Bumper from the rear.
- 8) Relocate OEM grille to WALD Front Bumper.
- 9) Temporarily fix all the clips, tapping screws, bolts and nuts to install WALD Front Bumper to the body.
- 10) Check all the details of the fitment, then fix them.

■ HOW TO INSTALL OEM MOLDINGS (STEP 5)

Cut OEM moldings according to the picture, then use caulking glue to install them to WALD Front Bumper.

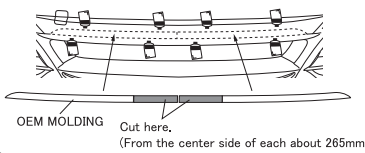

■ HOW TO INSTALL OEM HEADLIGHT WASHER PARTS (STEP 5)

Cut OEM headlight washer parts according to the picture, then use caulking glue to install them to WALD Front Bumper.



■ HOW TO INSTALL THE ATTACHED LED LAMPS (STEP 6)

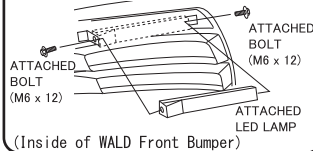

■ HOW TO INSTALL THE ATTACHED RESISTORS (STEP 3)

Connect the attached resistors to the harness of OEM headlights when the warning lamp is on.

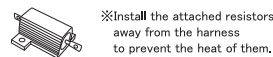

■ HOW TO INSTALL THE ATTACHED MESHES (STEP 7)

Use pins and caulking glue to install the attached meshes to WALD Front Bumper from the rear.

Cut the attached side-meshes into 2 pieces each if necessary.

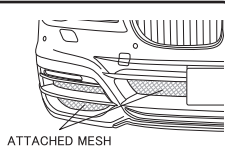

※ WALD SHOWCAR IS PAINTED LIKE THE PICTURE (STEP 4)

Paint the attached meshes in black, SILVER, GUN METALLIC

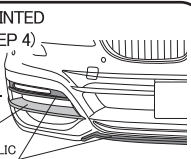

- ※ MORE THAN 2 TECHNICIANS ARE NECESSARY IN THIS WORK.
 - ※ DURING ALL THE INSTALLATION PROCESS, PLEASE BE CAREFUL NOT TO DAMAGE THE BODY.
- ATTENTION ※ REMOVE THE BATTERY BEFORE ALL THE WIRING WORKS.

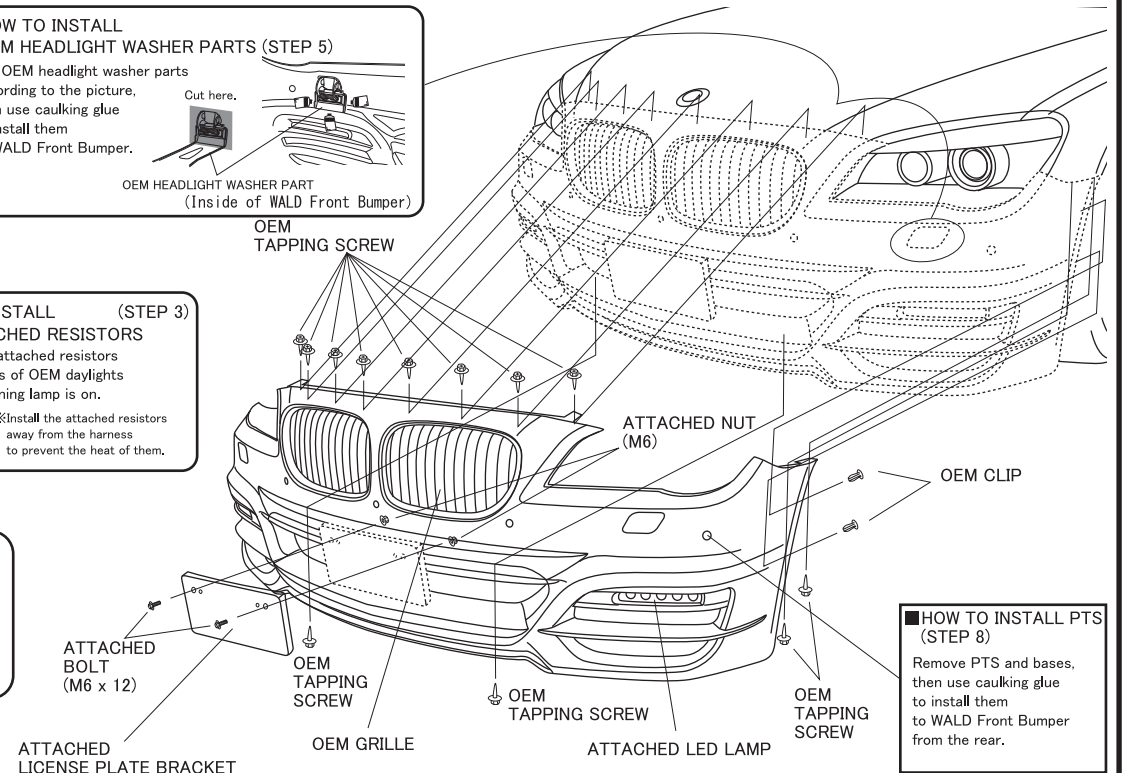

■ HOW TO INSTALL PTS (STEP 8)

Remove PTS and bases, then use caulking glue to install them to WALD Front Bumper from the rear.

BMW 7 Series F01/02

WALD SPORTS LINE
BLACK BISON EDITION

INSTALLATION MANUAL
WALD
Sportliche Autoausrüstung WALD.International

THANK YOU FOR PURCHASING. THIS IS THE INSTALLATION MANUAL OF WALD SIDE STEPS FOR BMW F01/02 7 SERIES.

ATTENTION



- ※ NO RETURNS CAN BE ACCEPTED BECAUSE OF IMPROPER INSTALLATION OR PAINTING.
- ※ CHECK THE FITMENT, AND ADJUST ALL THE DETAILS BEFORE PAINTING.
- We assume no responsibility for any damage resulting from improper installation, painting, modification and any cut wound in unsealing.
- Contact the car dealer when you have any question in removing OEM parts.
- During all the installation process, use parking brake and stop the engine completely.
- Use rasps or sandpapers to fit the products to the body if there is an individual difference.
- The product is made of FRP. Handle with care. Do not give the excessive force.
- Gradually fix the bolts and nuts by checking the fitment and balance of the installation.
- After making a hole on the body, make the corrosion treatment on it.
- Check the fitment, and adjust all the details of the fitment steady and proper.
- Please check the fitment and all the details regularly, fix the bolts and nuts as necessary.
- The instruction of painting is just our recommendation, please paint it as you like.
- ※ PLEASE BE AWARE OF:
- You may lose the warranty and all the services from the car maker, because of replacing OEM parts.
- Reduced road clearance may cause inconvenience in using parking curbs and garage jack.
- FRP, ABS and PPE products are slightly weaker than OEM parts in crashes.
- The product may not match the body and OEM color perfectly.

Please purchase double sided tape, primer and caulking glue at auto accessory shop or hardware store.

Completely degrease and paint primer on all the installation positions to enhance the viscosity of double sided tape.
Use dryer to warm double sided tape to enhance the viscosity in low temperature.
Keep the car in a dry condition more than 24 hours after gluing.
Do not wash the car during this time.

	PARTS	QUANTITIES
SIDE STEP	SIDE STEPS	1 SET

Use caulking glue to fill the gap between the product and the body.

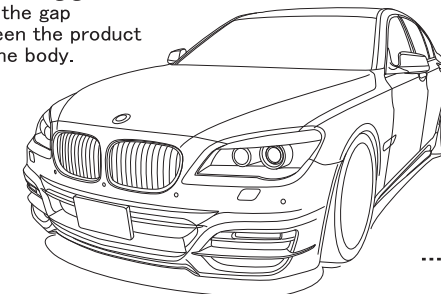

SIDE STEP

[BEFORE PAINTING]

- 1) Remove OEM side steps according to the BMW service manual.
 - 2) Use OEM tapping screws to fix OEM undercovers.
 - 3) Temporarily install WALD Side Steps to the body.
- ※ Adjust the details of WALD Side Steps to fit the body by rasps or sandpapers.
- 4) Paint WALD Side Steps according to the picture.

[AFTER PAINTING]

- 5) Completely degrease the installation positions of WALD Side Steps.
- 6) Temporarily fix OEM tapping screws to install WALD Side Steps to the body.
- 7) Check all the details of the fitment, then fix them.
- 8) Use masking tape to fix WALD Side Steps, leave them till completely fixed.

※WALD SHOWCAR IS PAINTED LIKE THE PICTURE (STEP 4)

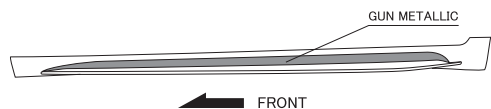

ATTENTION

- ※PROCESS EACH SIDE AT A TIME.
- ※MORE THAN 2 TECHNICIANS ARE NECESSARY IN THIS WORK. DURING ALL THE INSTALLATION PROCESS, PLEASE BE CAREFUL NOT TO DAMAGE THE BODY.
- ※DEGREASE ALL THE INSTALLATION POSITIONS, AND REMOVE THE BODY PROTECTION COATING BEFORE THE INSTALLATION.

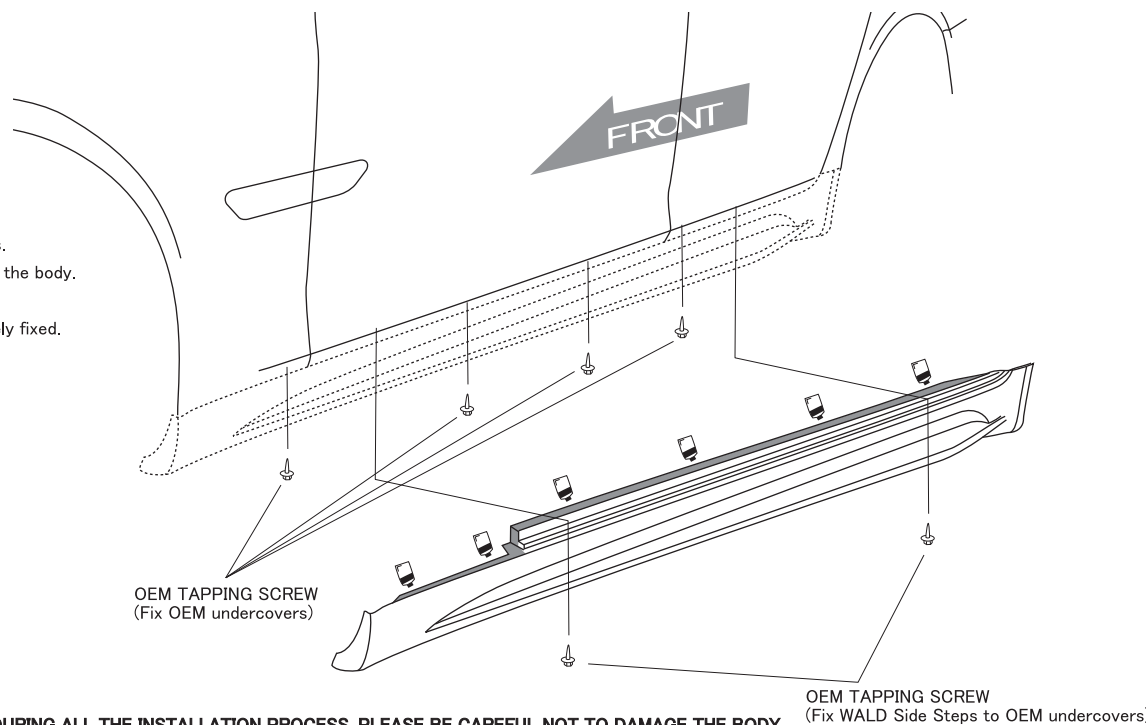

WALD INTERNATIONAL

BMW 7 Series F01/02

WALD SPORTS LINE
BLACK BISON EDITION

INSTALLATION MANUAL
WALD
Sportliche Autoausrüstung WALD.International

THANK YOU FOR PURCHASING. THIS IS THE INSTALLATION MANUAL OF WALD REAR BUMPER FOR BMW F01/02 7 SERIES.

ATTENTION



- ※ NO RETURNS CAN BE ACCEPTED BECAUSE OF IMPROPER INSTALLATION OR PAINTING.
- ※ CHECK THE FITMENT, AND ADJUST ALL THE DETAILS BEFORE PAINTING.
- We assume no responsibility for any damage resulting from improper installation, painting, modification and any cut wound in unsealing.
- Contact the car dealer when you have any question in removing OEM parts.
- During all the installation process, use parking brake and stop the engine completely.
- Use rasps or sandpapers to fit the products to the body if there is an individual difference.
- The product is made of FRP. Handle with care. Do not give the excessive force.
- Gradually fix the bolts and nuts by checking the fitment and balance of the installation.
- After making a hole on the body, make the corrosion treatment on it.
- Check the fitment, and adjust all the details of the fitment steady and proper.
- Please check the fitment and all the details regularly, fix the bolts and nuts as necessary.
- The instruction of painting is just our recommendation, please paint it as you like.
- ※ PLEASE BE AWARE OF:
- You may lose the warranty and all the services from the car maker, because of replacing OEM parts.
- Reduced road clearance may cause inconvenience in using parking curbs and garage jack.
- FRP, ABS and PPE products are slightly weaker than OEM parts in crashes.
- The product may not match the body and OEM color perfectly.

Please purchase double sided tape, primer and caulking glue at auto accessory shop or hardware store.

Completely degrease and paint primer on all the installation positions to enhance the viscosity of double sided tape.
Use dryer to warm double sided tape to enhance the viscosity in low temperature.
Keep the car in a dry condition more than 24 hours after gluing.
Do not wash the car during this time.

	PARTS	QUANTITIES
REAR BUMPER	REAR BUMPER	1
	MESHES	1 SET
	LED LAMP	1
	NUTS (M4)	2

Use caulking glue to fill the gap between the product and the body.

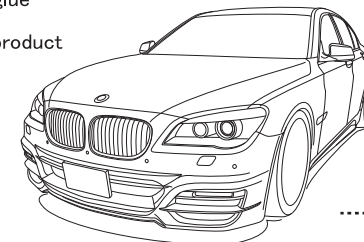

REAR BUMPER

【BEFORE PAINTING】

- 1) Remove OEM rear bumper according to the BMW service manual.
- 2) Temporarily install WALD Rear Bumper to the body.
- ※ Adjust the details of WALD Rear Bumper to fit the body by rasps or sandpapers.
- 3) Paint WALD Rear Bumper according to the picture.

【AFTER PAINTING】

- 4) Install the attached LED lamp to WALD Rear Bumper.
- ※ Make sure the attached LED lamp is fine to work before the installation.
- 5) Use pins and caulking glue to install the attached meshes to WALD Rear Bumper from the rear.
- 6) Relocate PTS and OEM reflectors to WALD Rear Bumper.
- 7) Temporarily fix OEM tapping screws and clips to install WALD Rear Bumper to the body.
- 8) Check all the details of the fitment, then fix them.

■ HOW TO INSTALL THE ATTACHED MESHES (STEP 5)

Use pins and caulking glue to install the attached meshes to WALD Rear Bumper from the rear.

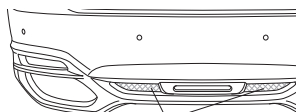

ATTACHED MESH

※WALD SHOWCAR IS PAINTED LIKE THE PICTURE (STEP 3)

Paint the attached meshes in black.

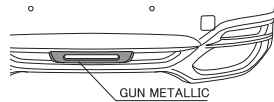

GUN METALLIC

■ HOW TO INSTALL THE ATTACHED LED LAMP (STEP 4)

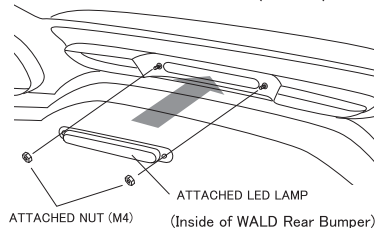

ATTACHED LED LAMP
ATTACHED NUT (M4)
(Inside of WALD Rear Bumper)

■ HOW TO INSTALL PTS (STEP 6)

Remove PTS and bases, then use caulking glue to install them to WALD Rear Bumper from the rear.

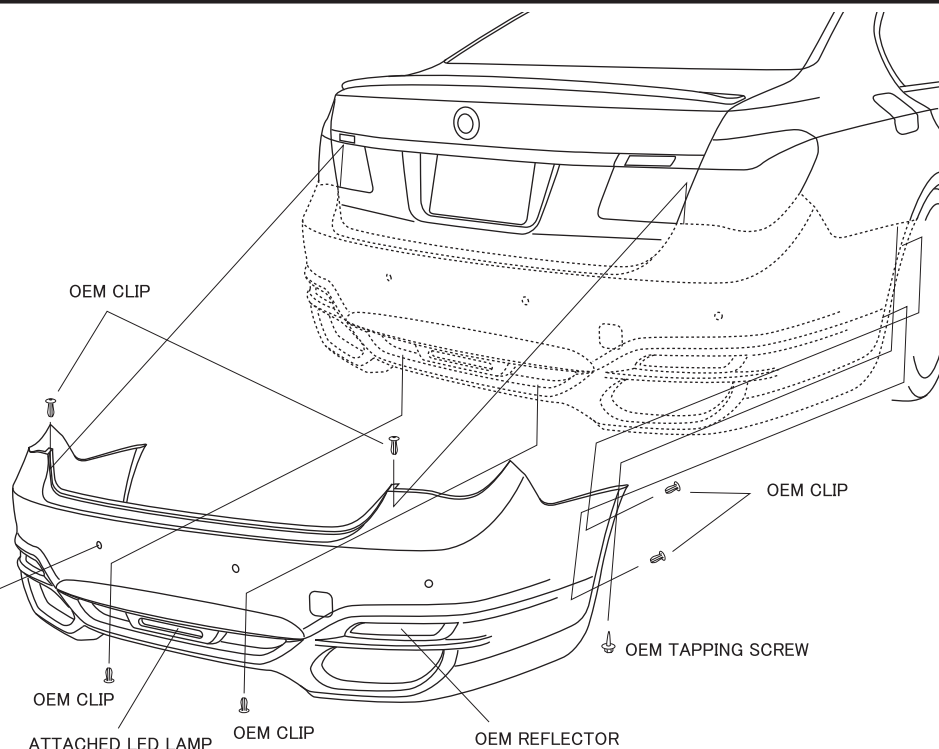

OEM CLIP

OEM CLIP

OEM TAPPING SCREW

OEM CLIP

ATTACHED LED LAMP

OEM CLIP

OEM REFLECTOR

ATTENTION

- ※ MORE THAN 2 TECHNICIANS ARE NECESSARY IN THIS WORK.
- ※ DURING ALL THE INSTALLATION PROCESS, PLEASE BE CAREFUL NOT TO DAMAGE THE BODY.
- ※ REMOVE THE BATTERY BEFORE ALL THE WIRING WORKS.

BMW 7 Series F01/02

WALD SPORTS LINE
BLACK BISON EDITION

INSTALLATION MANUAL
WALD
Sportliche Autoausrüstung WALD.International

THANK YOU FOR PURCHASING. THIS IS THE INSTALLATION MANUAL OF WALD TRUNK SPOILER AND ROOF SPOILER FOR BMW F01/02 7 SERIES.

ATTENTION



- ※ NO RETURNS CAN BE ACCEPTED BECAUSE OF IMPROPER INSTALLATION OR PAINTING.
- ※ CHECK THE FITMENT, AND ADJUST ALL THE DETAILS BEFORE PAINTING.
- We assume no responsibility for any damage resulting from improper installation, painting, modification and any cut wound in unsealing.
- Contact the car dealer when you have any question in removing OEM parts.
- During all the installation process, use parking brake and stop the engine completely.
- Use rasps or sandpapers to fit the products to the body if there is an individual difference.
- The product is made of FRP. Handle with care. Do not give the excessive force.
- Gradually fix the bolts and nuts by checking the fitment and balance of the installation.
- After making a hole on the body, make the corrosion treatment on it.
- Check the fitment, and adjust all the details of the fitment steady and proper.
- Please check the fitment and all the details regularly, fix the bolts and nuts as necessary.
- The instruction of painting is just our recommendation, please paint it as you like.
- ※ PLEASE BE AWARE OF:
 - You may lose the warranty and all the services from the car maker, because of replacing OEM parts.
 - Reduced road clearance may cause inconvenience in using parking curbs and garage jack.
 - FRP, ABS and PPE products are slightly weaker than OEM parts in crashes.
 - The product may not match the body and OEM color perfectly.

Please purchase double sided tape, primer and caulking glue at auto accessory shop or hardware store.

Completely degrease and paint primer on all the installation positions to enhance the viscosity of double sided tape.
Use dryer to warm double sided tape to enhance the viscosity in low temperature.
Keep the car in a dry condition more than 24 hours after gluing.
Do not wash the car during this time.

	PARTS	QUANTITIES
TRUNK SPOILER	TRUNK SPOILER	1
ROOF SPOILER	ROOF SPOILER	1



Use caulking glue to fill the gap between the product and the body.

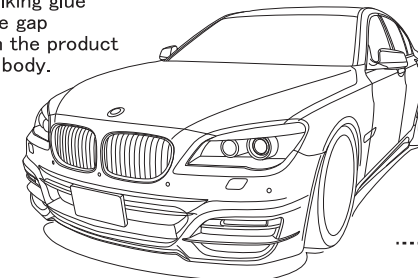

TRUNK SPOILER & ROOF SPOILER

【BEFORE PAINTING】

- 1) Temporarily install WALD Trunk Spoiler and Roof Spoiler to the body.
- 2) Check the fitment, then use masking tape to mark the installation positions.

【AFTER PAINTING】

- 3) Completely degrease the installation positions of WALD Trunk Spoiler and Roof Spoiler, then use caulking glue to install them to the body according to the marked positions.
- 4) Check all the details of the fitment, then use masking tape to fix them.
- 5) Leave them till completely fixed.

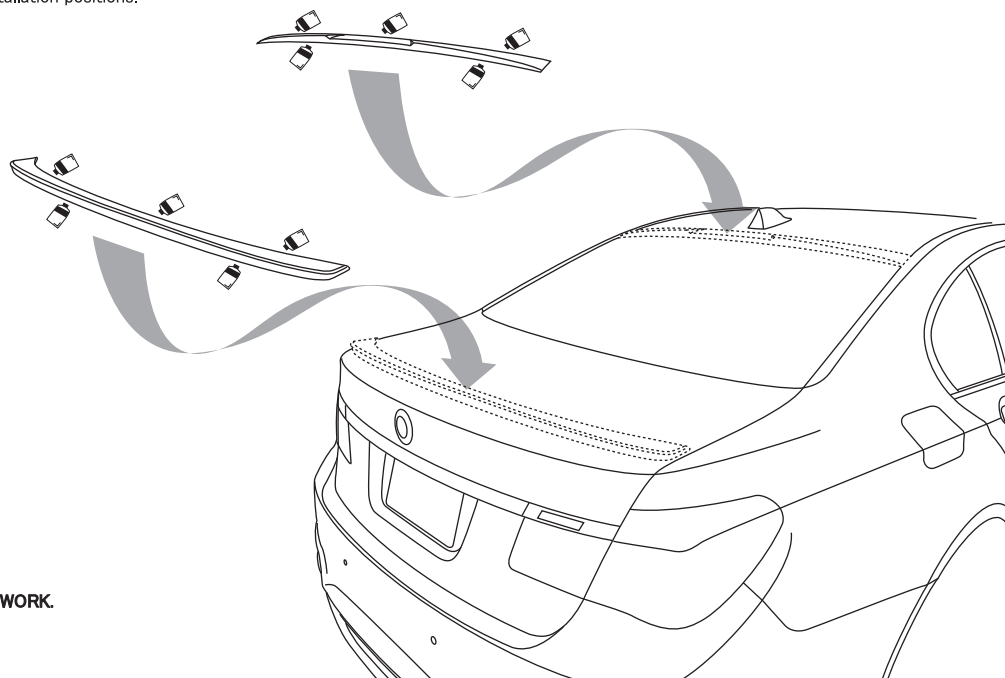

ATTENTION

※MORE THAN 2 TECHNICIANS ARE NECESSARY IN THIS WORK.
DURING ALL THE INSTALLATION PROCESS,
PLEASE BE CAREFUL NOT TO DAMAGE THE BODY.

※DEGREASE ALL THE INSTALLATION POSITIONS,
AND REMOVE THE BODY PROTECTION COATING BEFORE THE INSTALLATION.

WALD INTERNATIONAL