

JAGUAR XJ x350

WALD SPORTS LINE
BLACK BISON EDITION

INSTALLATION MANUAL
WALD
Sportliche Autoausrüstung WALD.International

THANK YOU FOR PURCHASING. THIS IS THE INSTALLATION MANUAL OF WALD FRONT BUMPER FOR JAGUAR XJ X350.

ATTENTION



- ※ NO RETURNS CAN BE ACCEPTED BECAUSE OF IMPROPER INSTALLATION OR PAINTING.
- ※ CHECK THE FITMENT, AND ADJUST ALL THE DETAILS BEFORE PAINTING.
- We assume no responsibility for any damage resulting from improper installation, painting, modification and any cut wound in unsealing.
- Contact the car dealer when you have any question in removing OEM parts.
- During all the installation process, use parking brake and stop the engine completely.
- Use rasps or sandpapers to fit the products to the body if there is an individual difference.
- The product is made of FRP. Handle with care. Do not give the excessive force. Gradually fix the bolts and nuts by checking the fitment and balance of the installation.
- After making a hole on the body, make the corrosion treatment on it.
- Check the fitment, and adjust all the details of the fitment steady and proper. Please check the fitment and all the details regularly, fix the bolts and nuts as necessary.
- The instruction of painting is just our recommendation, please paint it as you like.
- ※ PLEASE BE AWARE OF:
- You may lose the warranty and all the services from the car maker, because of replacing OEM parts.
- Reduced road clearance may cause inconvenience in using parking curbs and garage jack.
- FRP, ABS and PPE products are slightly weaker than OEM parts in crashes.
- The product may not match the body and OEM color perfectly.

Please purchase double sided tape, primer and caulking glue at auto accessory shop or hardware store.

Completely degrease and paint primer on all the installation positions to enhance the viscosity of double sided tape.
Use dryer to warm double sided tape to enhance the viscosity in low temperature.
Keep the car in a dry condition more than 24 hours after gluing.
Do not wash the car during this time.

	PARTS	QUANTITIES
FRONT BUMPER	FRONT BUMPER	1
	MESHES	1 SET
	LED LAMP KIT	1 SET
OPTIONAL PARTS	STAINLESS MESHES	1 SET

 Use caulking glue to fill the gap between the product and the body.

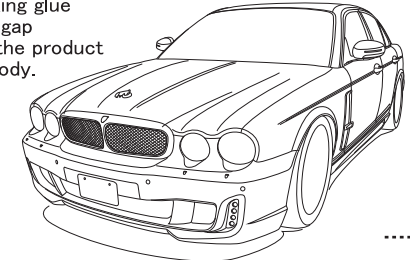

FRONT BUMPER

[BEFORE PAINTING]

- 1) Remove OEM front bumper according to the Jaguar service manual.
- 2) Relocate OEM U-type nuts to OEM undercover.
- ※ Adjust the details by cutting OEM undercover.
- 3) Relocate OEM parts to WALD Front Bumper, then temporarily install it to the body.
- ※ Adjust the details of WALD Front Bumper to fit the body by rasps or sandpapers.
- 4) Make holes to relocate OEM headlight washers according to the cutting line.

[AFTER PAINTING]

- 5) Use pins and caulking glue to install the attached meshes to WALD Front Bumper from the rear.
- 6) Install PTS and the attached LED lamp kit to WALD Front Bumper.
- ※ Make sure the attached LED lamps are fine to work before the installation.
- 7) Temporarily fix OEM bolts and U-type nuts to install WALD Front Bumper to the body.
- 8) Check all the details of the fitment, then fix them.

■ HOW TO INSTALL THE STAINLESS MESHES (Sold separately)

Install the stainless meshes according to the picture. Paint the attached meshes as necessary.

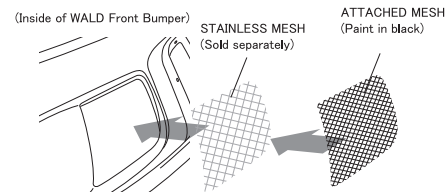

■ HOW TO INSTALL THE ATTACHED MESHES (STEP 5)

※Use pins and caulking glue to install the attached meshes to WALD Front Bumper from the rear.

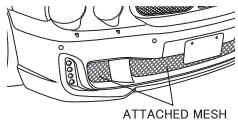

■ HOW TO INSTALL PTS (STEP 6)

Remove PTS and bases, then use caulking glue to install them to WALD Front Bumper.

ATTENTION

- ※MORE THAN 2 TECHNICIANS ARE NECESSARY IN THIS WORK.
- ※DURING ALL THE INSTALLATION PROCESS, PLEASE BE CAREFUL NOT TO DAMAGE THE BODY.
- ※REMOVE THE BATTERY BEFORE ALL THE WIRING WORKS.

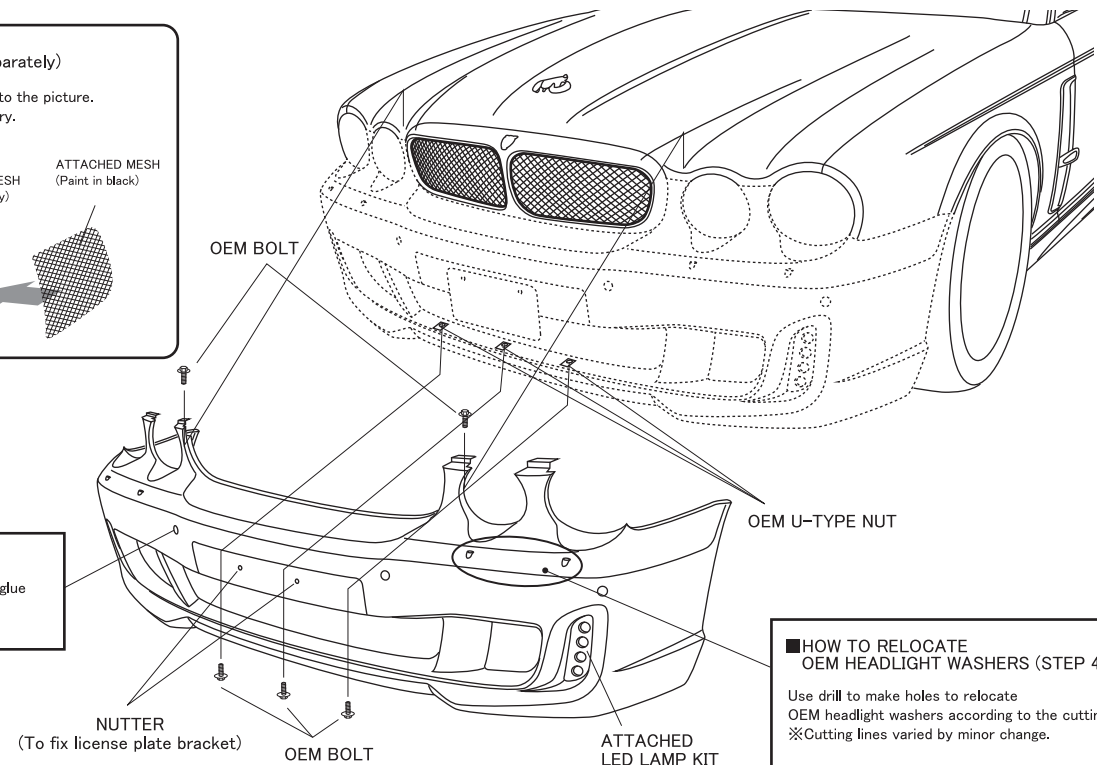

■ HOW TO RELOCATE OEM HEADLIGHT WASHERS (STEP 4)

Use drill to make holes to relocate OEM headlight washers according to the cutting line.
※Cutting lines varied by minor change.

JAGUAR XJ x350

WALD SPORTS LINE
BLACK BISON EDITION

INSTALLATION MANUAL
WALD
Sportliche Autoausrüstung WALD.International

THANK YOU FOR PURCHASING. THIS IS THE INSTALLATION MANUAL OF WALD SIDE STEPS FOR JAGUAR XJ X350.

ATTENTION



- ※ NO RETURNS CAN BE ACCEPTED BECAUSE OF IMPROPER INSTALLATION OR PAINTING.
- ※ CHECK THE FITMENT, AND ADJUST ALL THE DETAILS BEFORE PAINTING.
- We assume no responsibility for any damage resulting from improper installation, painting, modification and any cut wound in unsealing.
- Contact the car dealer when you have any question in removing OEM parts.
- During all the installation process, use parking brake and stop the engine completely.
- Use rasps or sandpapers to fit the products to the body if there is an individual difference.
- The product is made of FRP. Handle with care. Do not give the excessive force.
- Gradually fix the bolts and nuts by checking the fitment and balance of the installation.
- After making a hole on the body, make the corrosion treatment on it.
- Check the fitment, and adjust all the details of the fitment steady and proper.
- Please check the fitment and all the details regularly, fix the bolts and nuts as necessary.
- The instruction of painting is just our recommendation, please paint it as you like.
- ※ PLEASE BE AWARE OF:
- You may lose the warranty and all the services from the car maker, because of replacing OEM parts.
- Reduced road clearance may cause inconvenience in using parking curbs and garage jack.
- FRP, ABS and PPE products are slightly weaker than OEM parts in crashes.
- The product may not match the body and OEM color perfectly.

Please purchase double sided tape, primer and caulking glue at auto accessory shop or hardware store.

Completely degrease and paint primer on all the installation positions to enhance the viscosity of double sided tape.
Use dryer to warm double sided tape to enhance the viscosity in low temperature.
Keep the car in a dry condition more than 24 hours after gluing.
Do not wash the car during this time.

SIDE STEP	PARTS	
	SIDE STEPS	
	TAPPING SCREWS (M4 x 15)	2

Use caulking glue to fill the gap between the product and the body.

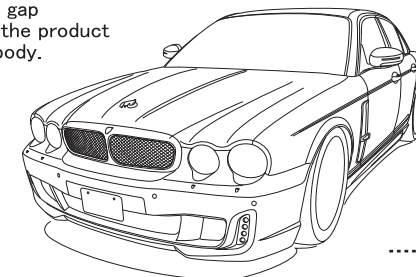

SIDE STEP

【BEFORE PAINTING】

- 1) Remove OEM side steps according to the Jaguar service manual.
- 2) Temporarily install WALD Side Steps to the body.
- ※ Adjust the details of WALD Side Steps to fit the body by rasps or sandpapers.
- 3) Mark the installation positions on the body according to WALD Side Steps.
- 4) Use drill to make holes on the body according to the marked positions.
- ※ Make corrosion treatment on the holes.
- 5) Paint WALD Side Steps according to the picture.

【AFTER PAINTING】

- 6) Completely degrease the installation positions of WALD Side Steps.
- 7) Temporarily fix all the tapping screws, bolts and use caulking glue to install WALD Side Steps to the body.
- 8) Check all the details of the fitment, then fix them.
- 9) Use masking tape to fix WALD Side Steps, leave them till completely fixed.

※WALD SHOWCAR IS PAINTED LIKE THE PICTURE (STEP 5)

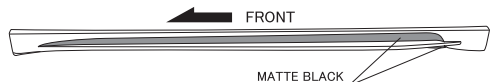

ATTENTION

- ※MORE THAN 2 TECHNICIANS ARE NECESSARY IN THIS WORK.
- ※DURING ALL THE INSTALLATION PROCESS, PLEASE BE CAREFUL NOT TO DAMAGE THE BODY.
- ※DEGREASE ALL THE INSTALLATION POSITIONS, AND REMOVE THE BODY PROTECTION COATING BEFORE THE INSTALLATION.

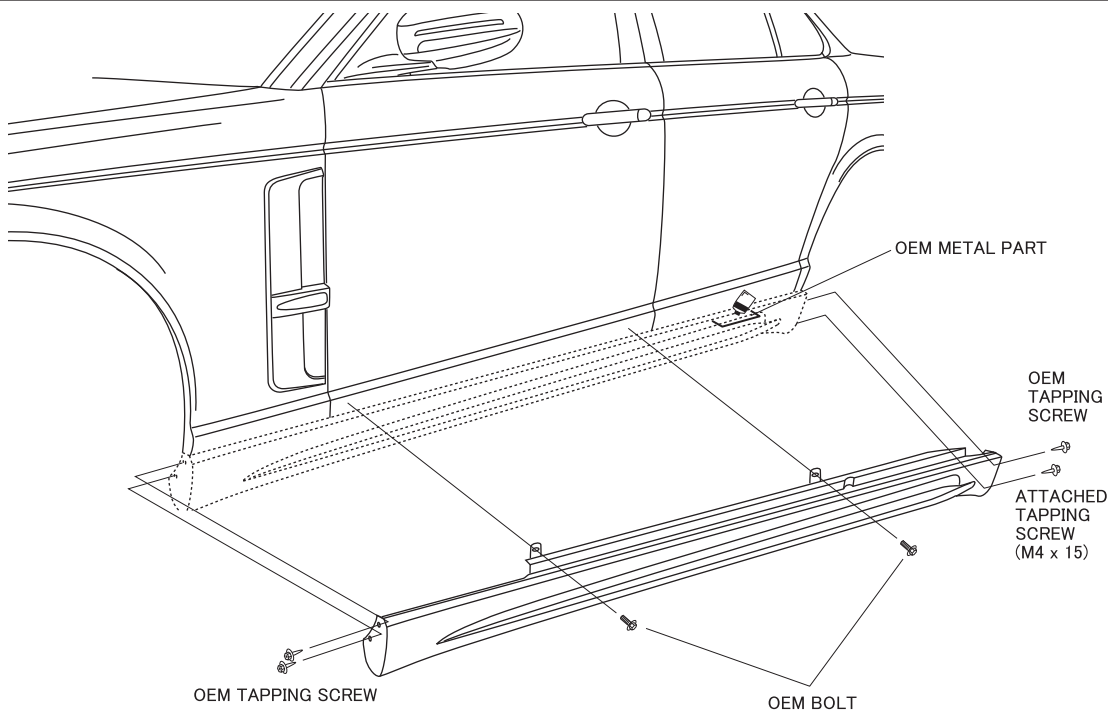

WALD INTERNATIONAL

JAGUAR XJ x350

WALD SPORTS LINE
BLACK BISON EDITION

INSTALLATION MANUAL
WALD
Sportliche Autoausrüstung WALD.International

THANK YOU FOR PURCHASING. THIS IS THE INSTALLATION MANUAL OF WALD REAR BUMPER FOR JAGUAR XJ X350.

ATTENTION



- ※ NO RETURNS CAN BE ACCEPTED BECAUSE OF IMPROPER INSTALLATION OR PAINTING.
- ※ CHECK THE FITMENT, AND ADJUST ALL THE DETAILS BEFORE PAINTING.
- We assume no responsibility for any damage resulting from improper installation, painting, modification and any cut wound in unsealing.
- Contact the car dealer when you have any question in removing OEM parts.
- During all the installation process, use parking brake and stop the engine completely.
- Use rasps or sandpapers to fit the products to the body if there is an individual difference.
- The product is made of FRP. Handle with care. Do not give the excessive force.
- Gradually fix the bolts and nuts by checking the fitment and balance of the installation.
- After making a hole on the body, make the corrosion treatment on it.
- Check the fitment, and adjust all the details of the fitment steady and proper.
- Please check the fitment and all the details regularly, fix the bolts and nuts as necessary.
- The instruction of painting is just our recommendation, please paint it as you like.
- ※ PLEASE BE AWARE OF:
- You may lose the warranty and all the services from the car maker, because of replacing OEM parts.
- Reduced road clearance may cause inconvenience in using parking curbs and garage jack.
- FRP, ABS and PPE products are slightly weaker than OEM parts in crashes.
- The product may not match the body and OEM color perfectly.

Please purchase double sided tape, primer and caulking glue at auto accessory shop or hardware store.

Completely degrease and paint primer on all the installation positions to enhance the viscosity of double sided tape.

Use dryer to warm double sided tape to enhance the viscosity in low temperature.

Keep the car in a dry condition more than 24 hours after gluing.

Do not wash the car during this time.

	PARTS	QUANTITIES
REAR BUMPER	REAR BUMPER	1
	MESHES	1 SET
	LED LAMP	1
	NUTS (M4)	2
	BRACKETS	2
	BOLTS (M5 x 15) & NUTS	4 SETS
OPTIONAL PARTS	TAPPING SCREWS (M4 x 15)	2
	STAINLESS MESHES	1 SET



Use caulking glue to fill the gap between the product and the body.

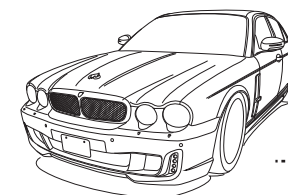

REAR BUMPER

[BEFORE PAINTING]

- 1) Remove OEM rear bumper according to the Jaguar service manual.
- 2) Relocate OEM U-type nuts to WALD Rear Bumper, then temporarily install it to the body.
- ※ Adjust the details of WALD Rear Bumper to fit the body by rasps or sandpapers.
- 3) Check the fitment, then mark the installation positions on the body according to WALD Rear Bumper.
- 4) Use drill to make holes according to the marked positions.
- ※ Make corrosion treatment on the holes.
- 5) Prepare to connect the attached LED lamp harness.
- ※ Insulate any spare harness.
- 6) Paint WALD Rear Bumper according to the picture.

[AFTER PAINTING]

- 7) Use pins and caulking glue to install the attached meshes to WALD Rear Bumper from the rear.
- 8) Install PTS and the attached LED lamp to WALD Rear Bumper.
- ※ Make sure the attached LED lamp is fine to work before the installation.
- 9) Relocate OEM parts to WALD Rear Bumper, then temporarily fix all the brackets, U-type nuts, bolts and nuts to install it to the body.
- 10) Check all the details of the fitment, then fix them.

※WALD SHOWCAR IS PAINTED LIKE THE PICTURE (STEP 6)



■HOW TO INSTALL THE ATTACHED MESHES (STEP 7)

Use pins and caulking glue to install the attached meshes to WALD Rear Bumper from the rear.

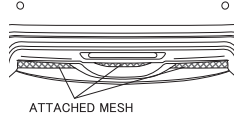

ATTACHED MESH

■HOW TO INSTALL THE STAINLESS MESHES (Sold separately)

Install the stainless meshes according to the picture. Paint the attached meshes as necessary.

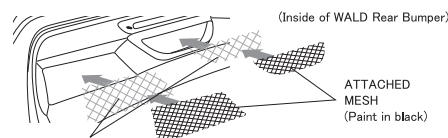

STAINLESS MESH (Sold separately)

※Cut WALD Rear Bumper according to the picture to install WALD Exhaust System.

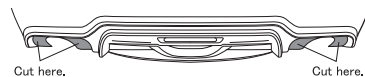

Cut here.

Cut here.

■HOW TO INSTALL THE ATTACHED LED LAMP (STEP 8)

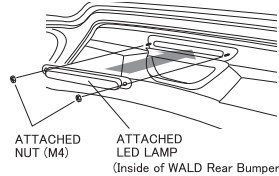

ATTACHED NUT (M4)

ATTACHED LED LAMP (Inside of WALD Rear Bumper)

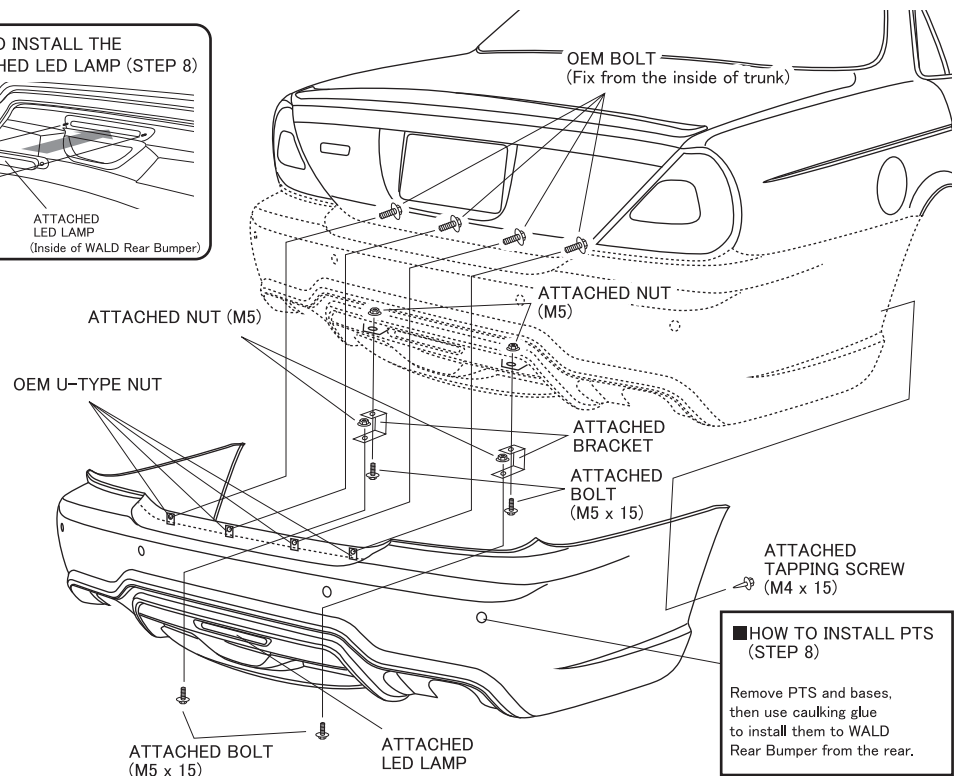

OEM BOLT (Fix from the inside of trunk)

ATTACHED NUT (M5)

ATTACHED NUT (M5)

OEM U-TYPE NUT

ATTACHED BRACKET

ATTACHED BOLT (M5 x 15)

ATTACHED TAPPING SCREW (M4 x 15)

ATTACHED BOLT (M5 x 15)

ATTACHED LED LAMP

■HOW TO INSTALL PTS (STEP 8)

Remove PTS and bases, then use caulking glue to install them to WALD Rear Bumper from the rear.



ATTENTION

- ※MORE THAN 2 TECHNICIANS ARE NECESSARY IN THIS WORK.
- ※DURING ALL THE INSTALLATION PROCESS, PLEASE BE CAREFUL NOT TO DAMAGE THE BODY.
- ※REMOVE THE BATTERY BEFORE ALL THE WIRING WORKS.

JAGUAR XJ X350

WALD SPORTS LINE
BLACK BISON EDITION

INSTALLATION MANUAL
WALD
Sportliche Autoausrüstung WALD.International

THANK YOU FOR PURCHASING. THIS IS THE INSTALLATION MANUAL OF WALD FENDER PANELS FOR JAGUAR XJ X350.

ATTENTION



- ※ NO RETURNS CAN BE ACCEPTED BECAUSE OF IMPROPER INSTALLATION OR PAINTING.
- ※ CHECK THE FITMENT, AND ADJUST ALL THE DETAILS BEFORE PAINTING.
- We assume no responsibility for any damage resulting from improper installation, painting, modification and any cut wound in unsealing.
- Contact the car dealer when you have any question in removing OEM parts.
- During all the installation process, use parking brake and stop the engine completely.
- Use rasps or sandpapers to fit the products to the body if there is an individual difference.
- The product is made of FRP. Handle with care. Do not give the excessive force.
- Gradually fix the bolts and nuts by checking the fitment and balance of the installation.
- After making a hole on the body, make the corrosion treatment on it.
- Check the fitment, and adjust all the details of the fitment steady and proper.
- Please check the fitment and all the details regularly, fix the bolts and nuts as necessary.
- The instruction of painting is just our recommendation, please paint it as you like.
- ※ PLEASE BE AWARE OF:
- You may lose the warranty and all the services from the car maker, because of replacing OEM parts.
- Reduced road clearance may cause inconvenience in using parking curbs and garage jack.
- FRP, ABS and PPE products are slightly weaker than OEM parts in crashes.
- The product may not match the body and OEM color perfectly.

Please purchase double sided tape, primer and caulking glue at auto accessory shop or hardware store.

Completely degrease and paint primer on all the installation positions to enhance the viscosity of double sided tape.
Use dryer to warm double sided tape to enhance the viscosity in low temperature.
Keep the car in a dry condition more than 24 hours after gluing.
Do not wash the car during this time.

	PARTS	QUANTITIES
FENDER PANEL	FENDER PANELS	1 SET
	WINKER LAMPS	1 SET

Use caulking glue to fill the gap between the product and the body.

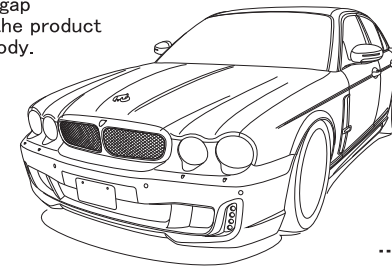

FENDER PANEL

【BEFORE PAINTING】

- 1) Temporarily install WALD Fender Panels to the body, then use masking tape to mark the installation positions.
- 2) Make use of OEM winker lamp harness to prepare to connect the attached winker lamps.
- ※ Make sure the attached winker lamps are fine to work before the installation.
- 3) Paint WALD Fender Panels according to the picture.

【AFTER PAINTING】

- 4) Use caulking glue to install the attached winker lamps to WALD Fender Panels from the rear.
- 5) Completely degrease the installation positions, then use caulking glue to install WALD Fender Panels to the body.
- 6) Check all the details of the fitment, leave them till completely fixed.

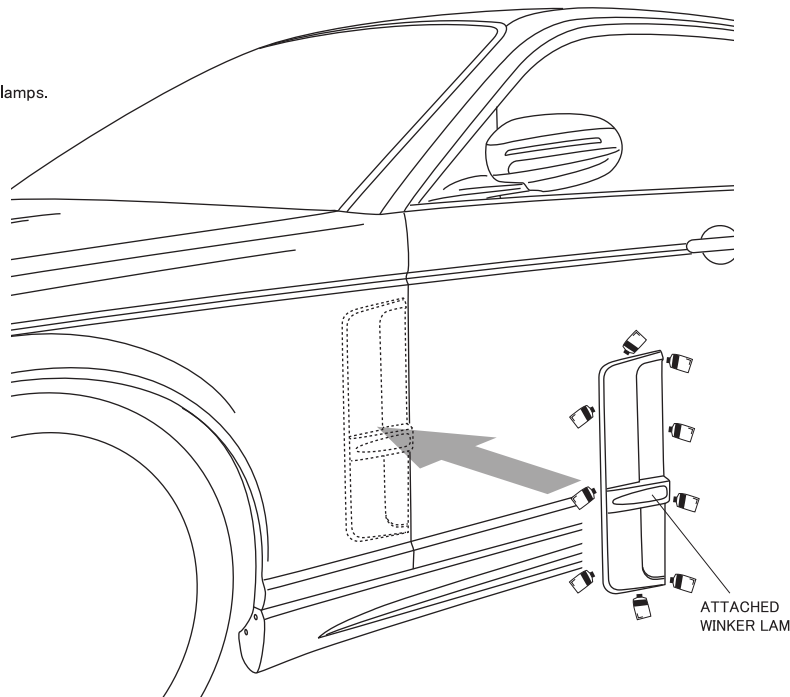

※WALD SHOWCAR IS PAINTED LIKE THE PICTURE (STEP 3)

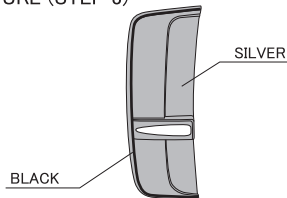

ATTENTION

- ※DEGREASE ALL THE INSTALLATION POSITIONS, AND REMOVE THE BODY PROTECTION COATING BEFORE THE INSTALLATION.
- ※REMOVE THE BATTERY BEFORE ALL THE WIRING WORKS.
- ※MAKE SURE THE ATTACHED WINKER LAMPS ARE FINE TO WORK BEFORE THE INSTALLATION.

■HOW TO INSTALL WALD FENDER PANELS (STEP 1,2)

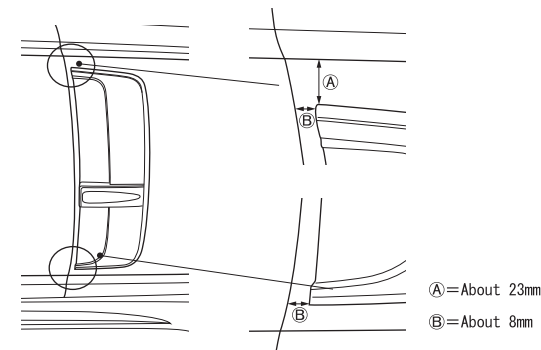

■HOW TO INSTALL THE ATTACHED WINKER LAMPS (STEP 4)

Use caulking glue to install the attached winker lamps to WALD Fender Panels from the rear.

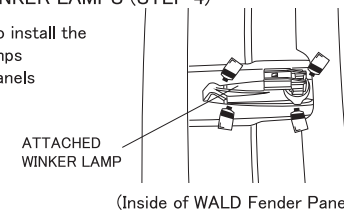

JAGUAR XJ X350

WALD SPORTS LINE
BLACK BISON EDITION

INSTALLATION MANUAL
WALD
Sportliche Autoausrüstung WALD.International

THANK YOU FOR PURCHASING. THIS IS THE INSTALLATION MANUAL OF WALD MIRROR COVERS FOR JAGUAR XJ X350.

ATTENTION



- ※ NO RETURNS CAN BE ACCEPTED BECAUSE OF IMPROPER INSTALLATION OR PAINTING.
- ※ CHECK THE FITMENT, AND ADJUST ALL THE DETAILS BEFORE PAINTING.
- We assume no responsibility for any damage resulting from improper installation, painting, modification and any cut wound in unsealing.
- Contact the car dealer when you have any question in removing OEM parts.
- During all the installation process, use parking brake and stop the engine completely.
- Use rasps or sandpapers to fit the products to the body if there is an individual difference.
- The product is made of FRP. Handle with care. Do not give the excessive force. Gradually fix the bolts and nuts by checking the fitment and balance of the installation.
- After making a hole on the body, make the corrosion treatment on it.
- Check the fitment, and adjust all the details of the fitment steady and proper. Please check the fitment and all the details regularly, fix the bolts and nuts as necessary.
- The instruction of painting is just our recommendation, please paint it as you like.
- ※ PLEASE BE AWARE OF:
 - You may lose the warranty and all the services from the car maker, because of replacing OEM parts.
 - Reduced road clearance may cause inconvenience in using parking curbs and garage jack.
 - FRP, ABS and PPE products are slightly weaker than OEM parts in crashes.
 - The product may not match the body and OEM color perfectly.

Please purchase double sided tape, primer and caulking glue at auto accessory shop or hardware store.

Completely degrease and paint primer on all the installation positions to enhance the viscosity of double sided tape.
Use dryer to warm double sided tape to enhance the viscosity in low temperature.
Keep the car in a dry condition more than 24 hours after gluing.
Do not wash the car during this time.

	PARTS	QUANTITIES
MIRROR COVER	MIRROR COVERS	1 SET
	LED LAMPS	1 SET

Use caulking glue to fill the gap between the product and the body.

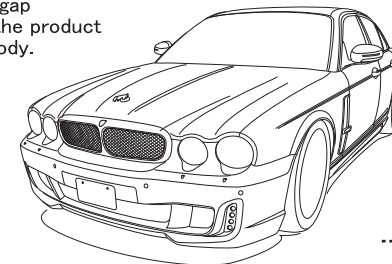

MIRROR COVER

【BEFORE PAINTING】

- 1) Remove OEM mirror covers according to the Jaguar service manual.
- 2) Cut the attached LED lamps according to the picture.
- ※ Adjust the details of WALD Mirror Covers to fit the attached LED lamps by rasps or sandpapers.
- 3) Temporarily install WALD Mirror Covers to the body.
- ※ Adjust the details of WALD Mirror Covers to fit the body by rasps or sandpapers.
- 4) Make use of OEM winker lamp harness to prepare to connect the attached LED lamps.
- ※ Make sure the attached LED lamps are fine to work before the installation.
- 5) Paint WALD Mirror Covers according to the picture.

【AFTER PAINTING】

- 6) Use caulking glue to fix the attached LED lamps to WALD Mirror Covers from the rear.
- 7) Completely degrease the installation positions, then use caulking glue to fix WALD Mirror Covers to the body.
- 8) Check all the details of the fitment, leave them till completely fixed.

■ HOW TO INSTALL THE ATTACHED LED LAMPS (STEP 2, 4, 6)

Cut the attached LED lamps according to the picture. Use caulking glue to fix the attached LED lamps to WALD Mirror Covers from the rear.

Make use of harness of OEM winker lamps to prepare to connect the attached LED lamps. (Remove the door panel to connect the LED lamp harness.)

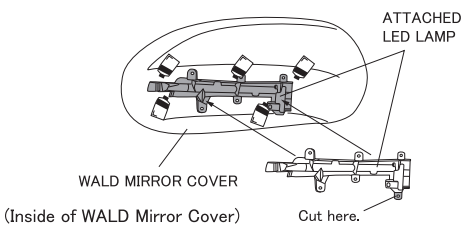

※WALD SHOWCAR IS PAINTED LIKE THE PICTURE (STEP 5)

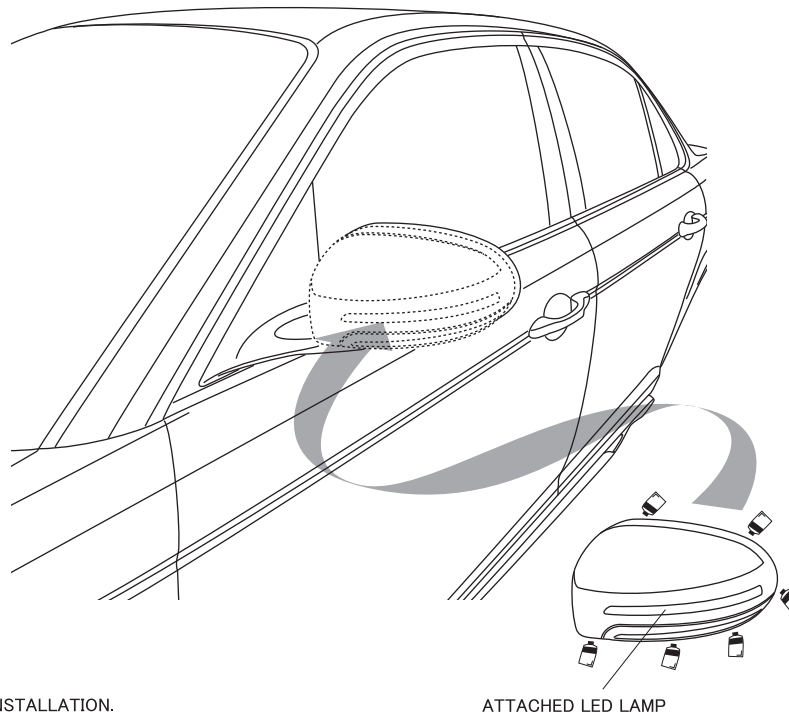
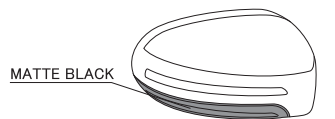

ATTENTION

- ※DURING ALL THE INSTALLATION PROCESS, PLEASE BE CAREFUL NOT TO DAMAGE THE BODY.
- ※DEGREASE ALL THE INSTALLATION POSITIONS, AND REMOVE THE BODY PROTECTION COATING BEFORE THE INSTALLATION.
- ※REMOVE THE BATTERY BEFORE ALL THE WIRING WORKS.

WALD INTERNATIONAL

JAGUAR XJ x350

WALD SPORTS LINE
BLACK BISON EDITION

INSTALLATION MANUAL
WALD
Sportliche Autoausrüstung WALD.International

THANK YOU FOR PURCHASING. THIS IS THE INSTALLATION MANUAL OF WALD TRUNK SPOILER AND ROOF SPOILER FOR JAGUAR XJ X350.

ATTENTION



- ※ NO RETURNS CAN BE ACCEPTED BECAUSE OF IMPROPER INSTALLATION OR PAINTING.
- ※ CHECK THE FITMENT, AND ADJUST ALL THE DETAILS BEFORE PAINTING.
- We assume no responsibility for any damage resulting from improper installation, painting, modification and any cut wound in unsealing.
- Contact the car dealer when you have any question in removing OEM parts.
- During all the installation process, use parking brake and stop the engine completely.
- Use rasps or sandpapers to fit the products to the body if there is an individual difference.
- The product is made of FRP. Handle with care. Do not give the excessive force.
- Gradually fix the bolts and nuts by checking the fitment and balance of the installation.
- After making a hole on the body, make the corrosion treatment on it.
- Check the fitment, and adjust all the details of the fitment steady and proper.
- Please check the fitment and all the details regularly, fix the bolts and nuts as necessary.
- The instruction of painting is just our recommendation, please paint it as you like.
- ※ PLEASE BE AWARE OF:
 - You may lose the warranty and all the services from the car maker, because of replacing OEM parts.
 - Reduced road clearance may cause inconvenience in using parking curbs and garage jack.
 - FRP, ABS and PPE products are slightly weaker than OEM parts in crashes.
 - The product may not match the body and OEM color perfectly.

Please purchase double sided tape, primer and caulking glue at auto accessory shop or hardware store.

Completely degrease and paint primer on all the installation positions to enhance the viscosity of double sided tape.
Use dryer to warm double sided tape to enhance the viscosity in low temperature.
Keep the car in a dry condition more than 24 hours after gluing.
Do not wash the car during this time.

	PARTS	QUANTITIES
TRUNK SPOILER	TRUNK SPOILER	1
ROOF SPOILER	ROOF SPOILER	1



Use caulking glue to fill the gap between the product and the body.

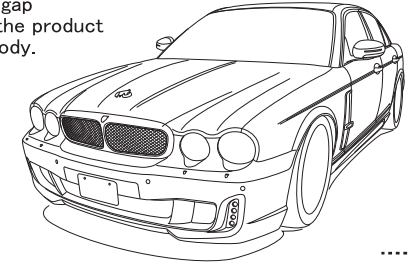

TRUNK SPOILER & ROOF SPOILER

【BEFORE PAINTING】

- 1) Temporarily install WALD Trunk Spoiler and Roof Spoiler to the body.
- 2) Check the fitment, then use masking tape to mark the installation positions.

【AFTER PAINTING】

- 3) Completely degrease the installation positions of WALD Trunk Spoiler and Roof Spoiler, then use caulking glue to install them to the body according to the marked positions.
- 4) Check all the details of the fitment, then use masking tape to fix them.
- 5) Leave them till completely fixed.

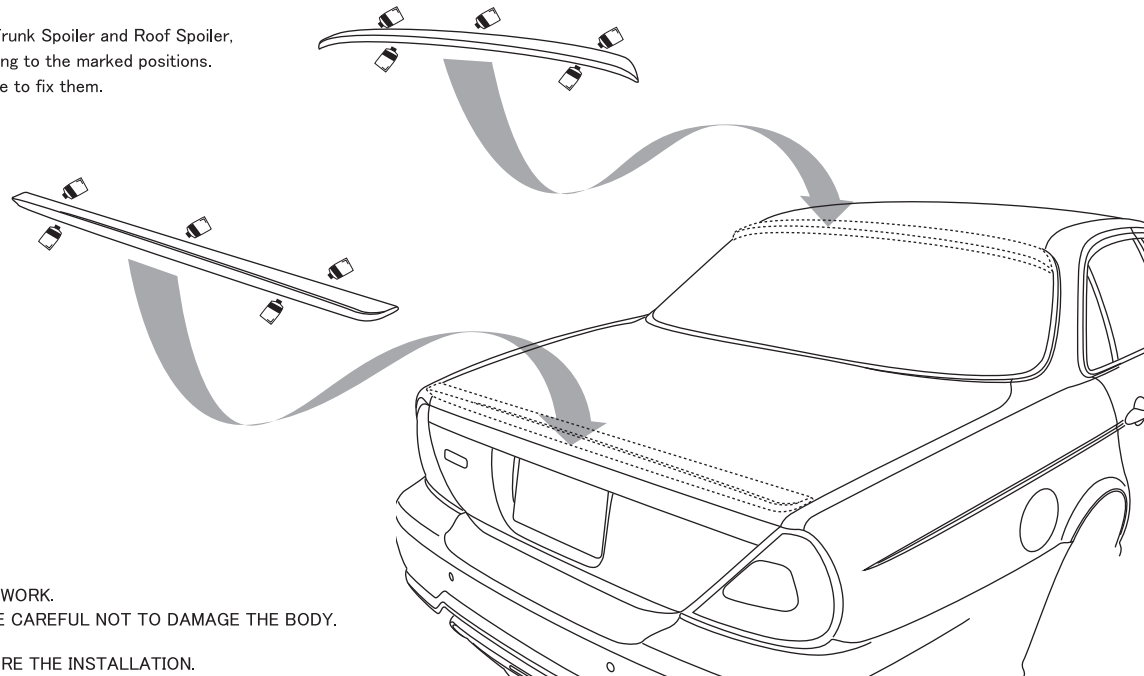

ATTENTION

- ※ MORE THAN 2 TECHNICIANS ARE NECESSARY IN THIS WORK.
- ※ DURING ALL THE INSTALLATION PROCESS, PLEASE BE CAREFUL NOT TO DAMAGE THE BODY.
- ※ DEGREASE ALL THE INSTALLATION POSITIONS, AND REMOVE THE BODY PROTECTION COATING BEFORE THE INSTALLATION.

WALD INTERNATIONAL

WALD INTERNATIONAL

WALD INTERNATIONAL

ADD: 10-13 KYOGUCHI-CHO, TAKATSUKI, OSAKA, JAPAN ZIP: 569-0072 TEL: (81)-72-673-3000 FAX: (81)-72-673-3003

JAGUAR XJ x350

WALD SPORTS LINE
BLACK BISON EDITION

INSTALLATION MANUAL
WALD
Sportliche Autoausrüstung WALD.International

THANK YOU FOR PURCHASING. THIS IS THE INSTALLATION MANUAL OF LED LAMP KIT OF WALD FRONT BUMPER FOR JAGUAR XJ X350.

ATTENTION



- ※ NO RETURNS CAN BE ACCEPTED BECAUSE OF IMPROPER INSTALLATION OR PAINTING.
- ※ CHECK THE FITMENT, AND ADJUST ALL THE DETAILS BEFORE PAINTING.
- We assume no responsibility for any damage resulting from improper installation, painting, modification and any cut wound in unsealing.
- Contact the car dealer when you have any question in removing OEM parts.
- During all the installation process, use parking brake and stop the engine completely.
- Use rasps or sandpapers to fit the products to the body if there is an individual difference.
- The product is made of FRP. Handle with care. Do not give the excessive force. Gradually fix the bolts and nuts by checking the fitment and balance of the installation.
- After making a hole on the body, make the corrosion treatment on it.
- Check the fitment, and adjust all the details of the fitment steady and proper. Please check the fitment and all the details regularly, fix the bolts and nuts as necessary.
- The instruction of painting is just our recommendation, please paint it as you like.
- ※ PLEASE BE AWARE OF:
- You may lose the warranty and all the services from the car maker, because of replacing OEM parts.
- Reduced road clearance may cause inconvenience in using parking curbs and garage jack.
- FRP, ABS and PPE products are slightly weaker than OEM parts in crashes.
- The product may not match the body and OEM color perfectly.

Please purchase double sided tape, primer and caulking glue at auto accessory shop or hardware store.

Completely degrease and paint primer on all the installation positions to enhance the viscosity of double sided tape.
Use dryer to warm double sided tape to enhance the viscosity in low temperature.
Keep the car in a dry condition more than 24 hours after gluing.
Do not wash the car during this time.

	PARTS	QUANTITIES
LED LAMP KIT	LED LAMPS	1 SET
	LED LAMP BRACKETS	1 SET
	BOLTS (M5 x 12)	8

Use caulking glue to fill the gap between the product and the body.

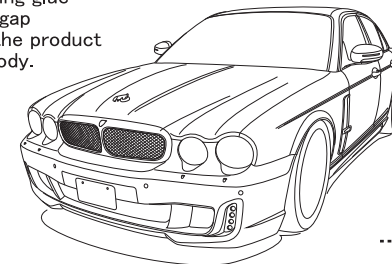

LED LAMP KIT

[BEFORE PAINTING]

- 1) Temporarily install the LED lamp brackets to WALD Front Bumper from the rear.
- ※ Adjust the details of LED lamp brackets to fit WALD Front Bumper by rasps or sandpapers.
- 2) Temporarily install the LED lamps to the LED lamp brackets.
- ※ Adjust the details of LED lamp brackets to fit the LED lamps by rasps or sandpapers.
- 3) Prepare to connect the LED lamp harness.
- ※ Insulate any spare harness.
- 4) Paint the LED lamp brackets according to the picture.

[AFTER PAINTING]

- 5) Use caulking glue to install the LED lamps to the LED lamp brackets.
- 6) Check all the details of the fitment, then use caulking glue to fix the LED lamps.
- 7) Install them to WALD Front Bumper.

※WALD SHOWCAR IS PAINTED LIKE THE PICTURE (STEP 4)

SILVER

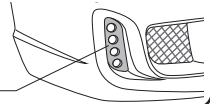

ATTENTION

- ※DEGREASE ALL THE INSTALLATION POSITIONS, AND REMOVE THE BODY PROTECTION COATING BEFORE THE INSTALLATION.
- ※REMOVE THE BATTERY BEFORE ALL THE WIRING WORKS.
- ※MAKE SURE THE LED LAMPS ARE FINE TO WORK BEFORE THE INSTALLATION.

HOW TO INSTALL THE LED LAMPS (STEP 2, 5)



(Face of the lens)

Fix the LED lamps according to the picture.

※Use heat resistant caulking glue to fix the LED lamps.

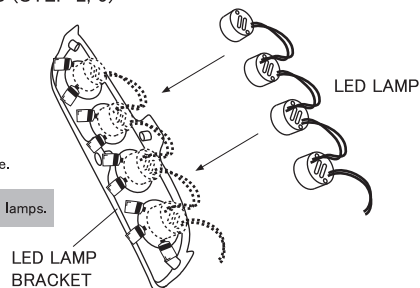

(Inside of WALD Front Bumper)

ATTACHED BOLT (M5 x 12)

ATTACHED NUTTER

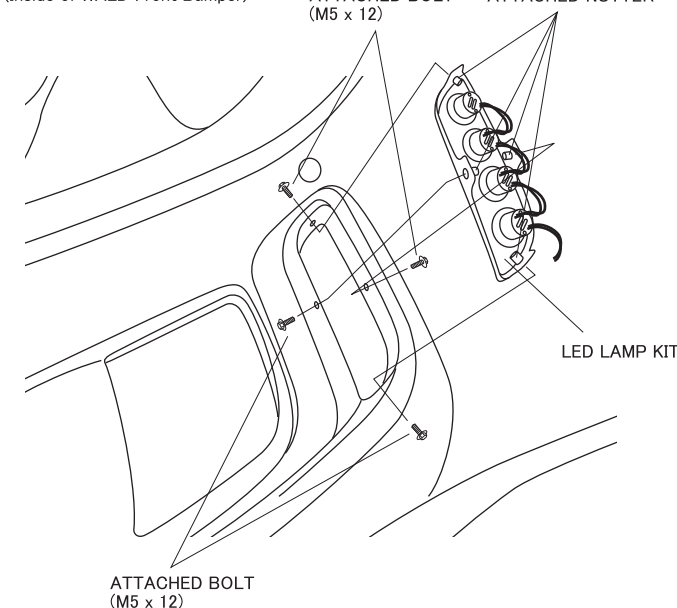

ATTACHED BOLT (M5 x 12)

«WIRING DIAGRAM»

