

LEXUS LX570

URJ201W(2015y~)

WALD SPORTS LINE

INSTALLATION MANUAL
WALD
Sportliche Autoausrüstung WALD.International

THANK YOU FOR PURCHASING. THIS IS THE INSTALLATION MANUAL OF WALD FRONT SPOILER FOR LEXUS LX570.
PLEASE READ THIS MANUAL CAREFULLY BEFORE THE INSTALLATION.

ATTENTION



- ※ NO RETURNS CAN BE ACCEPTED BECAUSE OF IMPROPER INSTALLATION OR PAINTING.
- ※ CHECK THE FITMENT, AND ADJUST ALL THE DETAILS BEFORE PAINTING.
- We assume no responsibility for any damage resulting from improper installation, painting, modification and any cut wound in unsealing.
- Contact the car dealer when you have any question in removing OEM parts.
- During all the installation process, use parking brake and stop the engine completely.
- Use rasps or sandpapers to fit the products to the body if there is an individual difference.
- The product is made of FRP. Handle with care. Do not give the excessive force.
- Gradually fix the bolts and nuts by checking the fitment and balance of the installation.
- Check the fitment, and adjust all the details of the fitment steady and proper.
- Please check the fitment and all the details regularly, fix the bolts and nuts as necessary.
- The instruction of painting is just our recommendation, please paint it as you like.
- ※ PLEASE BE AWARE OF:
- You may lose the warranty and all the services from the car maker, because of replacing OEM parts.
- Reduced road clearance may cause inconvenience in using parking curbs and garage jack.
- FRP, ABS and PPE products are slightly weaker than OEM parts in crashes.
- The product may not match the body and OEM color perfectly.

Please purchase double sided tape, primer and caulking glue at auto accessory shop or hardware store.

Completely degrease and paint primer on all the installation positions to enhance the viscosity of double sided tape.

Use dryer to warm double sided tape to enhance the viscosity in low temperature.
Keep the car in a dry condition more than 24 hours after gluing.
Do not wash the car during this time.

	PARTS	QUANTITIES
FRONT SPOILER	FRONT SPOILER	1
	CHROME ACCENT	1 SET
	RUBBER MOLDING (Black/Gray)	1 SET
	TAPPING SCREWS	2
	BRACKETS	1 SET
	BOLTS (M6 x 16)	2
	NUTS (M6)	2

Use caulking glue to fill the gap between the product and the body.

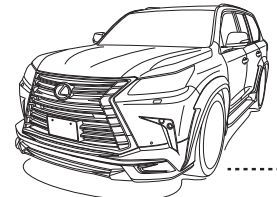

FRONT SPOILER

【BEFORE PAINTING】

- 1) Temporarily install WALD Front Spoiler to the body.
- ※ Adjust the details of WALD Front Spoiler to fit the body by rasps or sandpapers.
- 2) Mark the location of the holes for the attached tapping screws after checking the balance.
- 3) Take off WALD Front Spoiler, then make holes according to the marked positions.
- 4) Paint WALD Front Spoiler according to the picture.

【AFTER PAINTING】

- 5) Attach the brackets on WALD Front Spoiler according to the picture with the attached bolts and nuts.
- 6) Attach the rubber molding on WALD Front Spoiler.
- 7) Completely degrease the installation position.
- 8) Use caulking glue and the double sided tape to install WALD Front Spoiler to OEM front bumper, then fix all the attached tapping screws tightly.
- ※ The ends of the release paper of the double sided tape must be fold to adjust the location.
- 9) Use caulking glue and the double sided tape to fix the chrome accents on WALD Front Spoiler.
- 10) Leave it till completely fixed.

※WALD SHOWCAR IS PAINTED LIKE THE PICTURE (STEP 4)

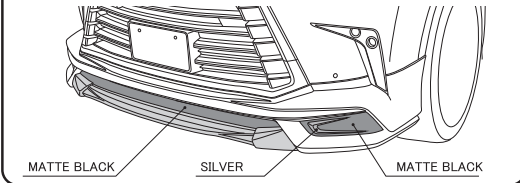

ATTENTION

- ※ MORE THAN 2 TECHNICIANS ARE NECESSARY IN THIS WORK.
- ※ DURING ALL THE INSTALLATION PROCESS, PLEASE BE CAREFUL NOT TO DAMAGE THE BODY.
- ※ ADJUST ALL THE DETAILS OF OUR PRODUCTS TO FIT ON A CAR PERFECTLY.

■HOW TO ATTACH THE RUBBER MOLDING (STEP 6)

Apply primer on the adhesion surface of WALD Front Spoiler before attaching the rubber moldings.

Adhesion Surface to WALD Front Spoiler

RUBBER MOLDING

OEM BOLT
※Through the attached bracket on WALD Front Spoiler

LONG HOLE
ATTACHED NUTS (M6)

CIRCLE HOLE
ATTACHED NUTS (M6)

ATTACHED BOLTS (M6 x 16)

ATTACHED BOLTS (M6 x 16)

ATTACHED CHROME ACCENT

OEM BOLT
※Through the attached bracket on WALD Front Spoiler

ATTACHED TAPPING SCREW

ATTACHED DOUBLE SIDED TAPE

※Use caulking glue and the attached double sided tape to fix

※ HOW TO INSTALL THE BRACKETS (STEP 5)

ATTACHED NUTS (M6)

ATTACHED BOLTS (M6 x 16)

LEXUS LX570

URJ201W(2015y~)

WALD SPORTS LINE

INSTALLATION MANUAL
WALD
Sportliche Autoausrüstung WALD.International

THANK YOU FOR PURCHASING. THIS IS THE INSTALLATION MANUAL OF WALD REAR SKIRT FOR LEXUS LX570.
PLEASE READ THIS MANUAL CAREFULLY BEFORE THE INSTALLATION.

ATTENTION



- ※ NO RETURNS CAN BE ACCEPTED BECAUSE OF IMPROPER INSTALLATION OR PAINTING.
- ※ CHECK THE FITMENT, AND ADJUST ALL THE DETAILS BEFORE PAINTING.
- We assume no responsibility for any damage resulting from improper installation, painting, modification and any cut wound in unsealing.
- Contact the car dealer when you have any question in removing OEM parts.
- During all the installation process, use parking brake and stop the engine completely.
- Use rasps or sandpapers to fit the products to the body if there is an individual difference.
- The product is made of FRP. Handle with care. Do not give the excessive force. Gradually fix the bolts and nuts by checking the fitment and balance of the installation.
- Check the fitment, and adjust all the details of the fitment steady and proper. Please check the fitment and all the details regularly, fix the bolts and nuts as necessary.
- The instruction of painting is just our recommendation, please paint it as you like.
- ※ PLEASE BE AWARE OF:
- You may lose the warranty and all the services from the car maker, because of replacing OEM parts.
- Reduced road clearance may cause inconvenience in using parking curbs and garage jack.
- FRP, ABS and PPE products are slightly weaker than OEM parts in crashes.
- The product may not match the body and OEM color perfectly.

Please purchase double sided tape, primer and caulking glue at auto accessory shop or hardware store.

Completely degrease and paint primer on all the installation positions to enhance the viscosity of double sided tape.

Use dryer to warm double sided tape to enhance the viscosity in low temperature.
Keep the car in a dry condition more than 24 hours after gluing.
Do not wash the car during this time.

	PARTS	QUANTITIES
REAR SKIRT	REAR SKIRT	1
	CHROME ACCENT	1
	STICKERS for CHROME ACCENT	5 PCS
	RUBBER MOLDING (Black/Gray)	1 SET

Use caulking glue to fill the gap between the product and the body.

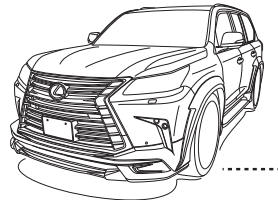

REAR SKIRT

[BEFORE PAINTING]

- 1) Temporarily install WALD Rear Skirt to the body.
- ※ Adjust the details of WALD Rear Skirt to fit the body by rasps or sandpapers.
- 2) Check the balance of the installation position of WALD Rear Skirt on OEM rear bumper.
- 3) Take Off OEM PTS and prepare to replace to WALD Rear Skirt (As per enclosure).
- ※ Need to take off OEM rear bumper spoiler from the body.
- 4) Paint WALD Rear Skirt according to the picture.

[AFTER PAINTING]

- 5) Install OEM PTS on WALD Rear Skirt (As per enclosure).
- ※ Make sure the LED lamp is fine to work before the installation.
- 6) Put the attached Rubber Molding on WALD Rear Skirt.
- 7) Completely degrease the installation position of WALD Rear Skirt and OEM rear bumper.
- 8) Use caulking glue and the attached double-sided tape to install WALD Rear Skirt to OEM rear bumper, then fix all OEM bolts tightly.
- ※ Fold the both ends of release paper of double sided tape to adjust the location.
- 9) Check all the details of the fitment.
- 10) Put the attached stickers on the Chrome Accent.
- 11) Fix the attached Chrome Accent on WALD Rear Skirt with caulking glue and the attached double-sided tape.
- 12) Leave it till completely fixed.

LOCATION OF WALD REAR SKIRT (STEP 2)

Straight Line from the borderline between OEM rear bumper and fender to WALD Rear Skirt.

ABOUT 290 mm

WALD SHOWCAR IS PAINTED LIKE THE PICTURE (STEP 4 & 10)

MATTE BLACK

ATTACHED STICKERS

HOW TO ATTACH THE RUBBER MOLDING (STEP 6)

Apply primer on the adhesion surface of WALD Front Spoiler before attaching the rubber moldings.

Adhesion Surface to WALD Front Spoiler

RUBBER MOLDING

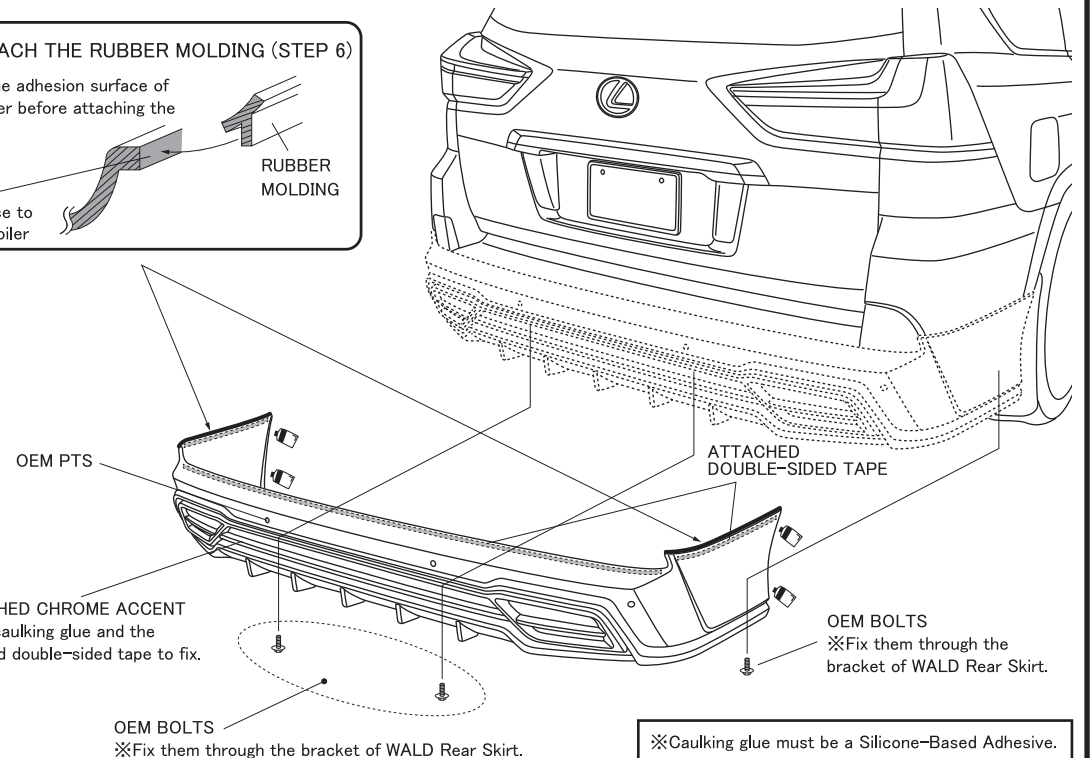

ATTENTION

- ※ MORE THAN 2 TECHNICIANS ARE NECESSARY IN THIS WORK.
- DURING ALL THE INSTALLATION PROCESS, PLEASE BE CAREFUL NOT TO DAMAGE THE BODY.
- ※ MAKE SURE THE ATTACHED LED LAMPS IS FINE TO WORK BEFORE THE INSTALLATION.
- ※ ADJUST ALL THE DETAILS OF OUR PRODUCTS TO FIT ON A CAR PERFECTLY.

※Caulking glue must be a Silicone-Based Adhesive.

THIS IS THE INSTALLATION MANUAL OF REPLACING PTS ON WALD REAR SKIRT FOR LEXUS LX570.

HOW TO REPLACE OEM PTS TO WALD FRONT SPOILER

- 1) Take off OEM Rear Bumper from the body, and take off OEM PTS with the whole basement from OEM Rear Bumper.
- 2) Cut OEM Rear Bumper according to the picture.
- 3) Put OEM Rear Bumper back to the body, then pull out the harness of PTS from the holes.
- 4) Fix OEM PTS on WALD Rear Skirt.

 Use caulking glue to fill the gap between the product and the body.

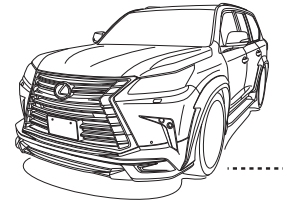

Please purchase double sided tape, primer and caulking glue at auto accessory shop or hardware store.

Completely degrease and paint primer on all the installation positions to enhance the viscosity of double sided tape.

Use dryer to warm double sided tape to enhance the viscosity in low temperature.

Keep the car in a dry condition more than 24 hours after gluing.

Do not wash the car during this time.

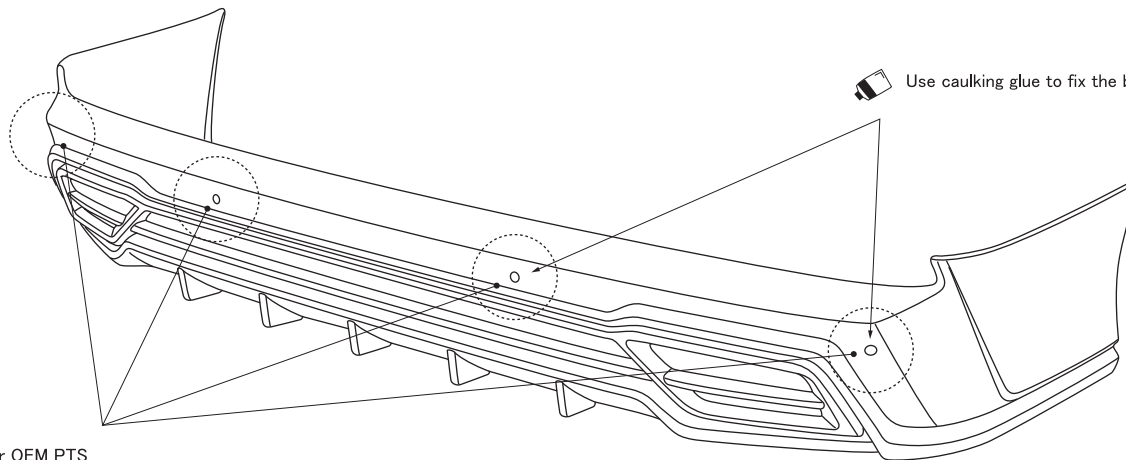
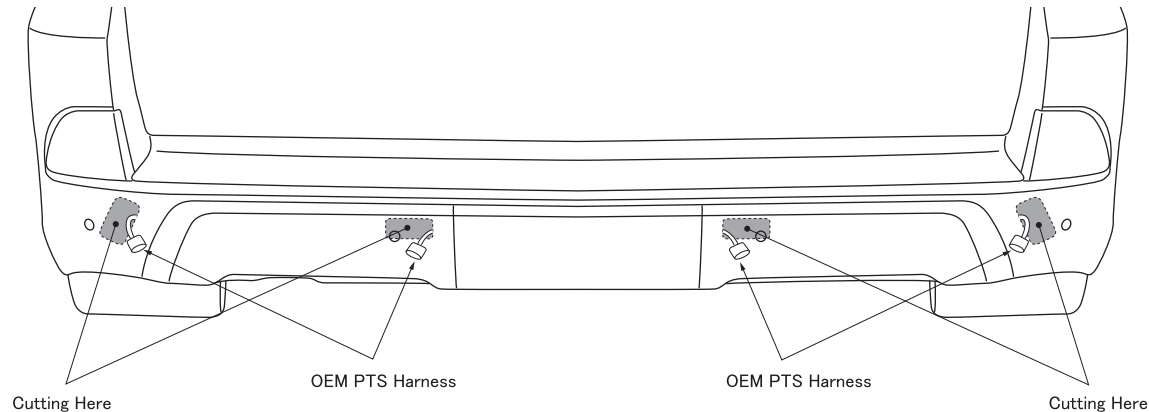

Locations for OEM PTS
(2 on Right and 2 on Left : Total 4)

THANK YOU FOR PURCHASING. THIS IS THE INSTALLATION MANUAL OF WALD REAR GATE SPOILER FOR LEXUS LX570.
PLEASE READ THIS MANUAL CAREFULLY BEFORE THE INSTALLATION.

ATTENTION



- ※ NO RETURNS CAN BE ACCEPTED BECAUSE OF IMPROPER INSTALLATION OR PAINTING.
- ※ CHECK THE FITMENT, AND ADJUST ALL THE DETAILS BEFORE PAINTING.
- We assume no responsibility for any damage resulting from improper installation, painting, modification and any cut wound in unsealing.
- Contact the car dealer when you have any question in removing OEM parts.
- During all the installation process, use parking brake and stop the engine completely.
- Use rasps or sandpapers to fit the products to the body if there is an individual difference.
- The product is made of FRP. Handle with care. Do not give the excessive force. Gradually fix the bolts and nuts by checking the fitment and balance of the installation.
- Check the fitment, and adjust all the details of the fitment steady and proper. Please check the fitment and all the details regularly, fix the bolts and nuts as necessary.
- The instruction of painting is just our recommendation, please paint it as you like.
- ※ PLEASE BE AWARE OF:
- You may lose the warranty and all the services from the car maker, because of replacing OEM parts.
- Reduced road clearance may cause inconvenience in using parking curbs and garage jack.
- FRP, ABS and PPE products are slightly weaker than OEM parts in crashes.
- The product may not match the body and OEM color perfectly.

Please purchase double sided tape, primer and caulking glue at auto accessory shop or hardware store.

Completely degrease and paint primer on all the installation positions to enhance the viscosity of double sided tape.

Use dryer to warm double sided tape to enhance the viscosity in low temperature.
Keep the car in a dry condition more than 24 hours after gluing.
Do not wash the car during this time.

	PARTS	QUANTITIES
REAR GATE SPOILER	REAR GATE SPOILER	1

Use caulking glue to fill the gap between the product and the body.

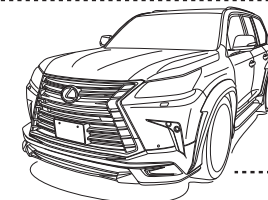

REAR GATE SPOILER

[BEFORE PAINTING]

- 1) Temporarily install WALD Rear Gate Spoiler to the body.
- 2) Mark the installation position on the body with masking tape, then remove WALD Rear Gate Spoiler.

[AFTER PAINTING]

- 3) Use caulking glue to install WALD Rear Gate Spoiler to the body after completely degreasing the installation position.
- 4) Leave it till completely fixed.

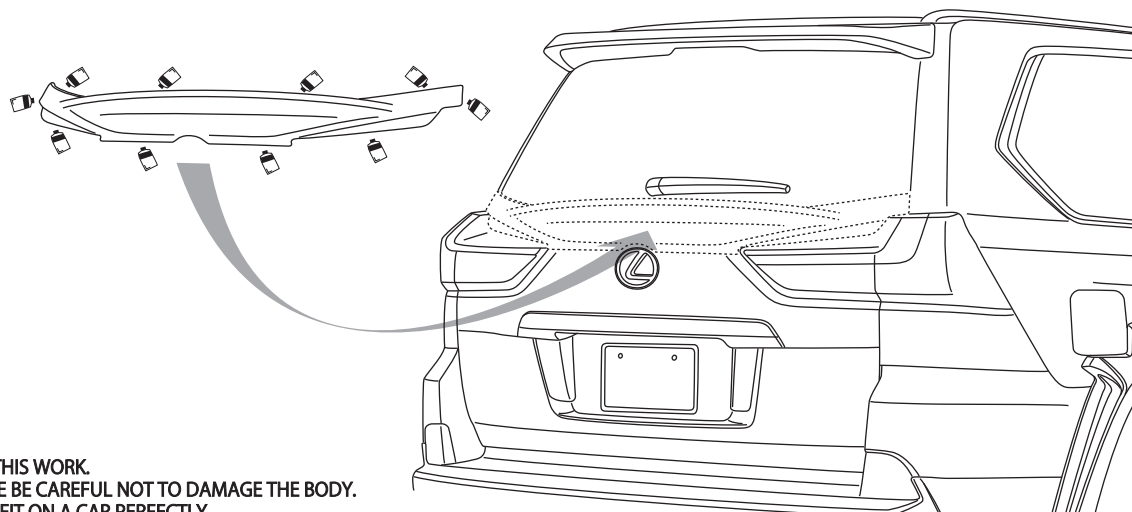

ATTENTION

- ※ MORE THAN 2 TECHNICIANS ARE NECESSARY IN THIS WORK.
- ※ DURING ALL THE INSTALLATION PROCESS, PLEASE BE CAREFUL NOT TO DAMAGE THE BODY.
- ※ ADJUST ALL THE DETAILS OF OUR PRODUCTS TO FIT ON A CAR PERFECTLY.

THANK YOU FOR PURCHASING. THIS IS THE INSTALLATION MANUAL OF WALD OVER FENDER FOR LEXUS LX570.
PLEASE READ THIS MANUAL CAREFULLY BEFORE THE INSTALLATION.

ATTENTION



- ※ NO RETURNS CAN BE ACCEPTED BECAUSE OF IMPROPER INSTALLATION OR PAINTING.
- ※ CHECK THE FITMENT, AND ADJUST ALL THE DETAILS BEFORE PAINTING.
- We assume no responsibility for any damage resulting from improper installation, painting, modification and any cut wound in unsealing.
- Contact the car dealer when you have any question in removing OEM parts.
- During all the installation process, use parking brake and stop the engine completely.
- Use rasps or sandpapers to fit the products to the body if there is an individual difference.
- The product is made of FRP. Handle with care. Do not give the excessive force. Gradually fix the bolts and nuts by checking the fitment and balance of the installation.
- Check the fitment, and adjust all the details of the fitment steady and proper. Please check the fitment and all the details regularly, fix the bolts and nuts as necessary.
- The instruction of painting is just our recommendation, please paint it as you like.
- ※ PLEASE BE AWARE OF:
- You may lose the warranty and all the services from the car maker, because of replacing OEM parts.
- Reduced road clearance may cause inconvenience in using parking curbs and garage jack.
- FRP, ABS and PPE products are slightly weaker than OEM parts in crashes.
- The product may not match the body and OEM color perfectly.

Please purchase double sided tape, primer and caulking glue at auto accessory shop or hardware store.

Completely degrease and paint primer on all the installation positions to enhance the viscosity of double sided tape.
Use dryer to warm double sided tape to enhance the viscosity in low temperature.
Keep the car in a dry condition more than 24 hours after gluing.
Do not wash the car during this time.

	PARTS	QUANTITIES
OVER FENDER	OVER FENDER	1 SET
	CHROME ACCENTS	1 SET
	TAPPING SCREWS (M4 x 15)	20

Use caulking glue to fill the gap between the product and the body.

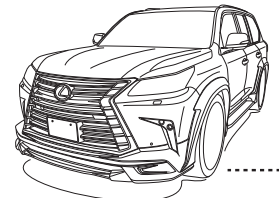

OVER FENDER

[BEFORE PAINTING]

- 1) Temporarily put WALD Over Fender to the body.
- ※ Adjust the details of WALD Over Fenders to the body by rasps or sandpapers.
- 2) Mark the installation positions on the body with masking tape after checking the fitting.
- 3) Make holes on WALD Over Fenders and the body to fix the attached tapping screws.
- 4) Paint WALD Over Fenders.

[AFTER PAINTING]

- 5) Completely degrease the installation positions.
- 6) Completely degrease the installation positions, then use caulking glue to install WALD Over Fenders to the body.
- 7) Use the attached double-sided tape and caulking glue to fix the attached chrome accents on WALD Over Fenders.
- 8) Leave them till completely fixed.

■ LOCATION OF ATTACHED ACCENT CHROME (STEP 7)

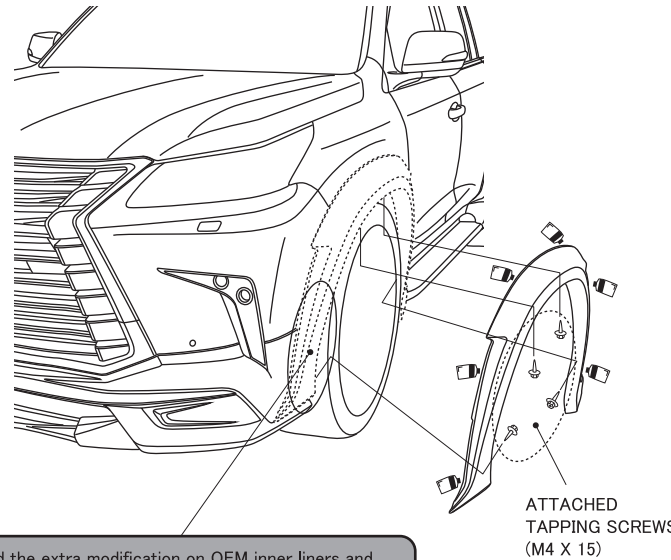
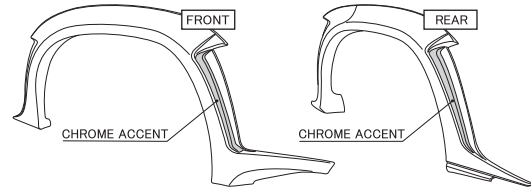

Need the extra modification on OEM inner liners and WALD Over Fenders when installing the wheels according to the width of WALD Over Fenders.

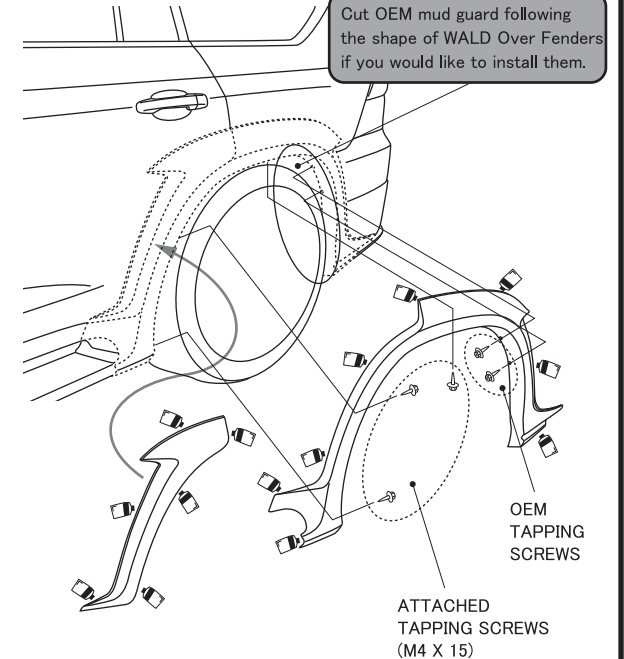

※Caulking glue must be a Silicone-Based Adhesive.

ATTENTION

- ※ MORE THAN 2 TECHNICIANS ARE NECESSARY IN THIS WORK.
- DURING ALL THE INSTALLATION PROCESS, PLEASE BE CAREFUL NOT TO DAMAGE THE BODY.
- ※ REMOVE THE BATTERY BEFORE ALL THE WIRING WORKS.
- ※ ADJUST ALL THE DETAILS OF OUR PRODUCTS TO FIT ON A CAR PERFECTLY.

THANK YOU FOR PURCHASING. THIS IS THE INSTALLATION MANUAL FOR THE EXTRA MODIFICATION AROUND THE FRONT WHEEL HOUSE OF LEXUS LX570.

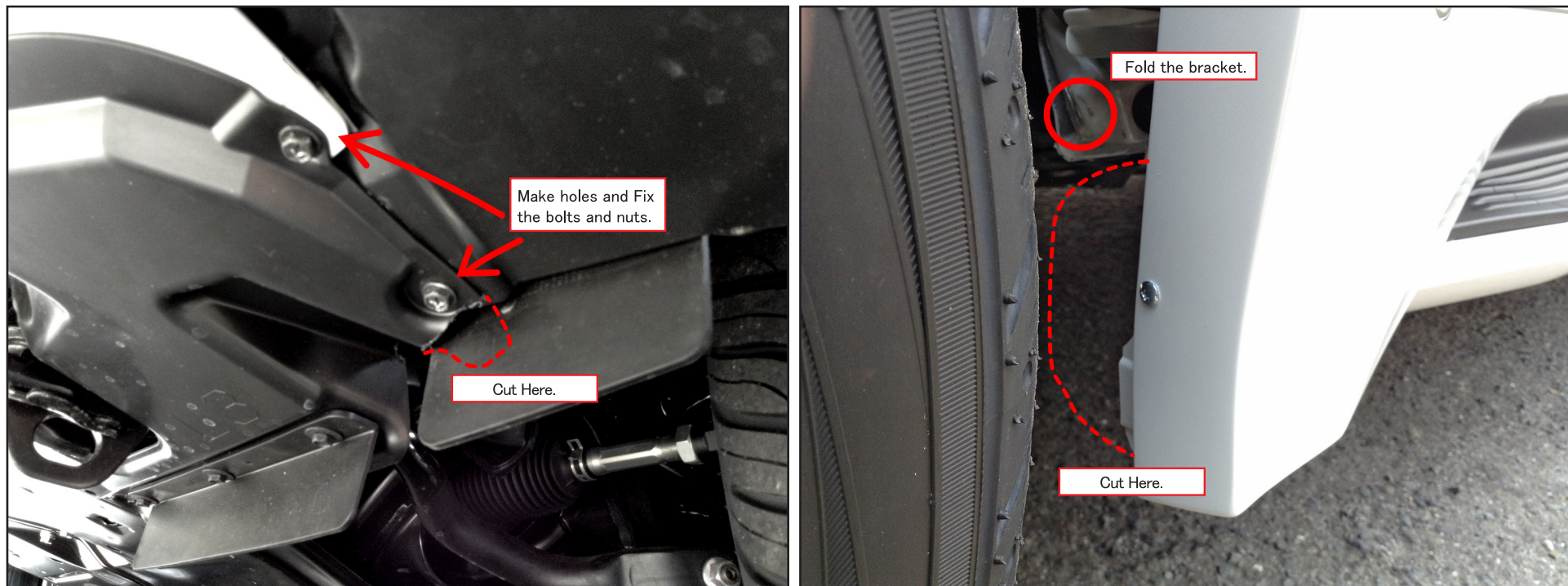

An Example for the Extra Modification to Install WALD Over Fender Size Wheel.